

New Rock Technologies, Inc.

MX Series Voice Gateway

User Manual

HX4E

MX8A

MX60

MX120

MX120G

Website: <http://www.newrocktech.com>

Email: gs@newrocktech.com

Document Version: 201606



Amendment Records

Document Rev. 01 (June 2016)

This manual is applicable to New Rock's MX series Voice Gateway V344.

Copyright © 2016 New Rock Technologies, Inc. All Rights Reserved.

All or part of this document may not be excerpted, reproduced and transmitted in any form or by any means without prior written permission from the company.

Contents

Amendment Records.....	2
Contents	3
Contents of Figure	6
Contents of Table	8
1 Overview.....	1
1.1 Product Introduction.....	1
1.2 Functions and Features	2
1.3 Equipment Structure	3
1.3.1 HX4E	3
1.3.2 MX8A.....	5
1.3.3 MX60	7
1.3.4 MX120	10
1.3.5 MX120G	15
2 Parameters Setting	20
2.1 Login	20
2.1.1 Obtaining Gateway IP Address.....	20
2.1.2 Logging On	20
2.1.3 Gateway Administrator and Operator Rights	21
2.2 Buttons Used on Gateway Management Interface.....	22
2.3 Basic Configuration.....	22
2.3.1 Status	22
2.3.2 Network	23
2.3.3 VLAN	24
2.3.4 System.....	26
2.3.5 SIP.....	28
2.3.6 High Availability	30
2.3.7 MGCP.....	31
2.3.8 FoIP	33
2.4 Line.....	35
2.4.1 Phone Number	35
2.4.2 Subscriber Line Features.....	36
2.4.3 Subscriber Line Batch (Unavailable on the HX4E)	38
2.4.4 Subscriber Line Characteristics	39
2.5 Trunk.....	42
2.5.1 Phone Number	42
2.5.2 Trunk Features	43
2.5.3 Trunk Batch (Unavailable on the HX4E)	44
2.5.4 Trunk Characteristics.....	45
2.6 Routing	47

2.6.1 Digit Map	47
2.6.2 Routing Table	49
2.6.3 Examples of Routing Rules	53
2.6.4 IP Table	54
2.7 Advanced Configuration.....	54
2.7.1 System.....	54
2.7.2 Auto Provisioning.....	56
2.7.3 Management System Type.....	57
2.7.4 Security Configuration	58
2.7.5 VPN (Available on the HX4E/MX8A)	59
2.7.6 Certificate	60
2.7.7 White list for Accessing Web and Telnet	61
2.7.8 Media Stream	61
2.7.9 SIP Configuration	62
2.7.10 RADIUS (Unavailable on the HX4E).....	66
2.7.11 Encryption.....	67
2.7.12 Greeting.....	68
2.7.13 Call Progress Tone Plan.....	69
2.7.14 Feature Codes.....	71
2.7.15 Clock Service.....	73
2.8 Status.....	75
2.8.1 Call Status	75
2.8.2 Call History on FXS	75
2.8.3 Call History on FXO.....	75
2.8.4 SIP Message Count.....	76
2.9 Logs.....	76
2.9.1 System Status	76
2.9.2 Call Message.....	78
2.9.3 System Startup	78
2.9.4 Manage Log.....	79
2.10 Tools	81
2.10.1 Change Password	81
2.10.2 Configuration Management	81
2.10.3 Upgrade.....	81
2.10.4 Restore Factory Settings	83
2.10.5 Capture Recordings on the Port	83
2.10.6 Ethereal Capture	84
2.10.7 Network Diagnosis.....	84
2.11 Product Information.....	85
2.12 Reboot	85
2.13 Logout.....	85
3 Appendix: VLAN Configuration.....	86
3.1 Automatic Discovery	86
3.1.1 LLDP.....	87
3.1.2 DHCP	90
3.2 Manual Configuration.....	92
3.2.1 Single VLAN	92
3.2.2 Multi-Service VLAN	93

4 Making an OpenVPN Client Certification 99

5 Appendix: High availability configuration..... 102

6 Appendix: Auto provisioning configuration 103

Contents of Figure

Figure 1-1 HX4E Front Panel.....	3
Figure 1-2 HX4E Back Panel.....	4
Figure 1-3 MX8A Front Panel.....	5
Figure 1-4 MX8A Back Panel.....	6
Figure 1-5 RJ45 to RS232 Serial Cable.....	6
Figure 1-6 USB to RS232 Converter Cable.....	6
Figure 1-7 MX60 Front Panel.....	8
Figure 1-8 Schematic Diagram of MX60 Subscriber Line Connection.....	9
Figure 1-9 MX60 Back Panel-AC.....	9
Figure 1-10 MX60 Back Panel-DC.....	9
Figure 1-11 MX120 Front Panel.....	10
Figure 1-12 Schematic Diagram of MX120 Subscriber Line Connection.....	11
Figure 1-13 MX120 Back Panel-AC.....	12
Figure 1-14 MX120 Back Panel-DC.....	13
Figure 1-15 MX120G Front Panel.....	15
Figure 1-16 Schematic Diagram of MX120G Subscriber Line Connection.....	16
Figure 1-17 MX120G Back Panel-AC.....	17
Figure 1-18 MX120G Back Panel-DC.....	17
Figure 2-19 Login Interface for MX8A Gateway Configuration.....	21
Figure 2-20 Status Interface.....	23
Figure 2-21 Network Configuration Interface.....	23
Figure 2-22 VLAN Configuration Interface.....	25
Figure 2-23 System Configuration Interface.....	27
Figure 2-24 SIP Configuration Interface.....	29
Figure 2-25 High Availability Configuration Interface.....	30
Figure 2-26 MGCP Configuration Interface.....	32
Figure 2-27 Fax Configuration Interface.....	34
Figure 2-28 Configuration Interface for Phone Number.....	35
Figure 2-29 Subscriber Line Features Configuration Interface.....	36
Figure 2-30 Feature Batch Configuration Interface.....	39
Figure 2-31 Subscriber Line Characteristics Configuration Interface.....	40
Figure 2-32 Phone Number Configuration Interface.....	42
Figure 2-33 Trunk Line Features Configuration Interface.....	43
Figure 2-34 Trunk Batch Configuration Interface.....	45
Figure 2-35 Trunk Characteristics Configuration Interface.....	46
Figure 2-36 Configuration Interface for Digit Map.....	48
Figure 2-37 Routing Table Configuration Interface.....	50
Figure 2-38 IP Table Configuration Interface.....	54
Figure 2-39 Interface of system advanced configuration.....	55
Figure 2-40 Interface of Auto Provisioning Configuration.....	56
Figure 2-41 SNMP Configuration Interface.....	57
Figure 2-42 TR069 Configuration Interface.....	57
Figure 2-43 Security Configuration Interface.....	58
Figure 2-44 VPN Configuration Interface.....	60
Figure 2-45 Certificate Configuration Interface.....	60
Figure 2-46 White List Configuration Interface.....	61

Figure 2-47 Media Stream Configuration Interface	62
Figure 2-48 SIP Related Configuration Interface	63
Figure 2-49 RADIUS Configuration Interface	66
Figure 2-50 Encryption Configuration Interface	67
Figure 2-51 Greeting Interface	69
Figure 2-52 Call Progress Tone Configuration Interface	70
Figure 2-53 Feature Codes Configuration Interface	71
Figure 2-54 Clock Service Interface	73
Figure 2-55 Call Status Interface	75
Figure 2-56 Interface of Call History on FXS	75
Figure 2-57 Interface of Call on FXO	76
Figure 2-58 SIP Message Count Interface	76
Figure 2-59 System Status Interface	77
Figure 2-60 Call Message Interface	78
Figure 2-61 Interface of System Startup	79
Figure 2-62 Manage Log Interface	79
Figure 2-63 Log Saving Interface	80
Figure 2-64 Path Saving Interface	80
Figure 2-65 Password Change Interface	81
Figure 2-66 Configuration Management Interface	81
Figure 2-67 Upgrade Interface	82
Figure 2-68 File Upload Interface	82
Figure 2-69 Upgrade Interface	82
Figure 2-70 Upgrade Process Screen	82
Figure 2-71 Interface for Completing Device Restart after Upgrade	83
Figure 2-72 Restore Factory Settings Interface	83
Figure 2-73 Interface for Capturing Port Recordings	83
Figure 2-74 Ethereal Capture Interface	84
Figure 2-75 Automatic Diagnosis Interface	84
Figure 2-76 Ping Diagnosis Interface	84
Figure 3-77 Scenario Diagram	88
Figure 3-78 Procedure of Handling LLDP Message Carrying a VLAN ID	89
Figure 3-79 Procedure of Handling the LLDP Message with no VLAN ID	89
Figure 3-80 LLDP Message	90
Figure 3-81 Adding a VLAN ID to the Message to Be Sent	90
Figure 3-82 Configuring the Single VLAN	93
Figure 3-83 A Data Packet Carrying a Corresponding VLAN Tag in the Single VLAN Mode	93
Figure 3-84 Configuring Voice VLAN to Work in Mode 1	94
Figure 3-85 Configuring Voice VLAN to Work in Mode 2	95
Figure 3-86 Configuring Management VLAN	96
Figure 3-87 Network Environment	96
Figure 3-88 Configuring Multi-Service VLAN	97
Figure 3-89 IP Addresses of the Device in Multi-Service VLAN	97
Figure 3-90 SIP Data Packet Carrying VLAN Tag of the Voice VLAN in the Multi-Service VLAN Mode	98
Figure 3-91 RTP Data Packet Carrying VLAN Tag of the Voice VLAN in the Multi-Service VLAN Mode	98
Figure 3-92 RTP Data Packet Carrying VLAN Tag of the Management VLAN in the Multi-Service VLAN Mode	98

Contents of Table

Table 1-1 MX Series Gateway Hardware Specifications.....	1
Table 1-2 Configuration Combination of HX4E	3
Table 1-3 Description of HX4E Front Panel	3
Table 1-4 Description of HX4E Back Panel	4
Table 1-5 Indicator Status of HX4E.....	4
Table 1-6 Configuration Combination of MX8A.....	5
Table 1-7 Voice Interface Cards Supported by the MX8A	5
Table 1-8 Description of MX8A Front Panel.....	5
Table 1-9 Description of MX8A Back Panel	6
Table 1-10 Indicator Status of MX8A	6
Table 1-11 Configuration Combination of MX60	8
Table 1-12 Description of MX60 Front Panel	8
Table 1-13 Pin Specifications for MX60 RJ45 Socket Port	8
Table 1-14 Description of MX60 Back Panel	9
Table 1-15 Meanings of MX60 Indicators	10
Table 1-16 MX120 Interface Card.....	10
Table 1-17 Configuration Combination of MX120	10
Table 1-18 Description of MX120 Front Panel.....	11
Table 1-19 Pin Specifications for MX120 RJ45 Socket Port	11
Table 1-20 Corresponding Relation Between MX120 RJ45 Socket and Line Number	12
Table 1-21 MX120 Back Panel	13
Table 1-22 Meanings of MX120 Indicators	13
Table 1-23 MX120 System Operation State	13
Table 1-24 MX120G Interface Card.....	15
Table 1-25 Configuration Combination of MX120G	15
Table 1-26 Description of MX120G Front Panel	15
Table 1-27 Pin Specifications for MX120G RJ45 Socket Port	16
Table 1-28 Corresponding Relation Between MX120G RJ45 Socket and Line Number	16
Table 1-29 MX120G Back Panel.....	18
Table 1-30 Meanings of MX120G Indicators.....	18
Table 1-31 MX120G System Operation State.....	19
Table 2-1 Default IP Address of Gateway.....	20
Table 2-2 Default Passwords of Gateway.....	21
Table 2-3 Network Configuration Parameters.....	23
Table 2-4 VLAN Configuration Parameters.....	25
Table 2-5 System Configuration Parameters	27
Table 2-6 Codec Methods Supported by Gateways.....	28
Table 2-7 SIP Configuration Parameters	29
Table 2-8 Parameters	30
Table 2-9 MGCP Configuration Parameters	32
Table 2-10 Fax Configuration Parameters.....	34
Table 2-11 Configuration Parameters of Phone Number	35
Table 2-12 Subscriber Line Features Configuration Parameters	36
Table 2-13 Subscriber Line Characteristics Configuration Parameter	40
Table 2-14 Configuration Parameters of FXO Phone Number.....	42
Table 2-15 Configuration Parameters of Trunk Features.....	43

Table 2-16 Trunk Characteristics Configuration Parameter 46

Table 2-17 Description of Digit Map 48

Table 2-18 Routing Table Format 51

Table 2-19 Number Transformations 51

Table 2-20 Routing Destination 52

Table 2-21 NAT Configuration Parameters 55

Table 2-22 Auto Provisioning Configuration Parameters 56

Table 2-23 SNMP Configuration Parameters 57

Table 2-24 TR069 Configuration Parameters 58

Table 2-25 Security Configuration Parameters 59

Table 2-26 VPN Configuration Parameters 60

Table 2-27 Media Stream Configuration Parameter 62

Table 2-28 SIP Related Configuration Parameter 64

Table 2-29 RADIUS Configuration Parameter 66

Table 2-30 Encryption Configuration Parameters 67

Table 2-31 Greeting Configuration Parameters 69

Table 2-32 Call Progress Tone Configuration Parameters 70

Table 2-33 Feature Codes Configuration Parameter 72

Table 2-34 Clock Service Parameters 74

Table 2-35 System Status Parameters 77

Table 2-36 Log Management Configuration Parameters 79

1 Overview

1.1 Product Introduction

MX Series intelligent VoIP Gateways (MX Gateways) are designed to bridge the traditional telecom terminal device into IP networks through SIP or MGCP protocols. The main applications include:

- For carriers and value-added service providers to provide telephone, fax and voice-band data services to subscribers using IP access methods such as FTTB, HFC, and ADSL;
- To bridge the traditional telecom terminal equipment, such as PBXs, to the VoIP core networks of carriers;
- To connect with an enterprise PBX to provide IP-based voice private network solutions for institutions, enterprises and schools;
- To be used as remote access equipment for IP-PBXs in call center deployment

The MX family has four sub-series: HX4E, MX8A, MX60, MX120 and MX120G, which mainly differ in port capacities.

Table 1-1 MX Series Gateway Hardware Specifications

Model	Voice ports	Chassis	Installation	CPU	RAM	Flash	Power
HX4E	2 - 4	Plastic Casing	Desktop	MIPS34Kc, 700MHz, SOC	64MB	16MB	12 VDC
MX8A	4 - 8	Metal	Desktop or rack	MIPS34Kc, 700MHz, SOC	128MB	16MB	12 VDC
MX60	16 - 48	19 inch Wide and 1U High	Rack	AT91SAM9G20B	64MB	16MB	100-240 VAC, -48 VDC (Optional)
MX120	48 - 96	19 inch Wide and 2U High	Rack	MPC8247	128MB	16MB	100-240 VAC, -48 VDC (Optional)
MX120 G	48 - 96	19 inch Wide and 2U High	Rack	TI A8, 1GHz	256MB	32MB	100-240 VAC, -36 to -72 VDC (optional) Dual power (optional)

Hardware for MX series gateways uses high-performance CPUs, ensuring that each product of the series can achieve full-capacity concurrent calls with high speech quality.

MX gateways software adopts the stable and reliable embedded Linux operating system (OS), implementing scores of business phone functions, including: call forwarding, call transfer, call hold, teleconference, caller identification, Do Not Disturb, ringback tone, hunt group simultaneous ring,

distinctive ring, one phone with two numbers, and fax. In addition, MX gateways are featured with FXO port second stage dialing with voice prompt, routing table with a maximum of 500 entries, phone digit manipulation, and PSTN failover upon power-off or network disconnection.

MX gateways support local and remote management operations through Web GUI or Telnet/SSH, SNMPv2-based and TR069/TR104/TR106-based centralized management schemes, and auto provisioning. Maintenance tasks such as modifying configuration, upgrading software, collecting statistical data, downloading logs, and fault alarms can be performed.

Note: PSTN failover upon power-off is supported by devices with both the FXS port and the FXO port.

1.2 Functions and Features

- Connect analog telephone, PBX, facsimile machine and POS machine to the IP core network, or PSTN
- Work with a service platform to provide various telephone supplementary services
- Support protocols: SIP, MGCP
- Support STUN. Detecting changes of the reflexive address of the device via STUN, and then triggering re-registration to the SIP registrar server.
- Flexible configuration of subscriber/trunk interfaces
- Support G.711, G.729
- Support echo cancellation
- Up to 500 routing rules can be stored in gateways
- Intercom
- Support concurrent calls under full load
- Support call progress tones for various countries and regions
- Support Line second stage dialing or voice prompt
- Support PSTN failover on power or network failure
- Security strategy: IP filter, encryption
- Support PSTN failover through FXO ports
- Support G.711 fax pass-through and T.38 fax relay
- Support polarity inverse detection and busy tone detection
- 3-way calling
- Compatible with unified communication solutions, such as CallManager, Lync, Asterisk and FreeSWITCH
- Support SNMPv2 and TR069/TR104/TR106
- Support Web GUI-based management , Telnet/SSH, automatic software upgrades, and configuration downloading
- Support high availability, implementing a cloud of SIP servers working in primary-standby or load balancing mode
- Support auto provisioning
- Support security settings such as whitelists

- Message waiting indications (MWI) with high voltage, FSK, or reversed polarity
- Support accessing the Web GUI by using HTTPS
- Support Ping blocking
- Support optional voice interface cards (only supported by the MX8A/MX120/MX120G)
- Support the VPN client (only available with the HX4E/MX8A)
- Support VLAN

1.3 Equipment Structure

1.3.1 HX4E

The HX4E adopts a compact plastic structural design and can be placed on a desk.

It provides either two or four FXS/FXO ports.

The HX4E supports the following models.

Table 1-2 Configuration Combination of HX4E

Models	Number of FXS Ports	Number of FXO Ports
HX402E	2	0
HX420E	0	2
HX422E	2	2
HX440E	0	4
HX404E	4	0

Figure 1-1 HX4E Front Panel



Table 1-3 Description of HX4E Front Panel

Item	Description
	Power Indicator
WAN	WAN interface indicator
PC	PC interface indicator
FXO/FXS	FXS /FXO port indicator

Figure 1-2 HX4E Back Panel



Table 1-4 Description of HX4E Back Panel

Item	Description
PWR	Power interface, 12 VDC input
PC and WAN	The PC port is used to connect a computer. The WAN port is used to connect the uplink network. Both are 10/100 Mbps Ethernet ports (RJ45). They share one IP address, which, by default, is obtained through DHCP. If no IP address is obtained, 192.168.2.218 is used by default, and you can change it on Basic > Network page.
FXO/FXS	FXS port or FXO port

Table 1-5 Indicator Status of HX4E

Indicator	Status	Description
PWR(green)	Blinking green	The device is starting.
	Steady green	The device is running.
	Off	The device is powered off or a power supply fault occurred
STU (red, green)	Steady red	The WAN interface failed to acquire the IP address. Possibly the WAN interface is not connected to a network cable, the WAN interface address failed to be acquired by DHCP, the IP addresses are conflicted, and the PPPoE dialing failed.
	Blinking red	The device is starting or the KUPDATE is upgrading.
	Steady green	Registration is successful.
	Blinking alternatively between red and green	Registration failed.
	Blinking green	Calling.
	Off	Registration has not started.
WAN (green)	Steady green	A WAN connection is established without any service flow.
	Blinking green	A WAN connection is established with service flow.
	Off	WAN interface is disconnected.
PC (green)	Steady green	A link is connected without any service flow.
	Blinking green	A service flow is being transmitted.
	Off	A link is not connected.
	Steady green	Off-hook or call established

Indicator	Status	Description
FXS/FXO (green)	Blinking green	Ringling on incoming call
	Off	The port is in idle status

1.3.2 MX8A

The MX8A adopts a compact metal structural design. It can be placed on a desk or installed in a standard communications cabinet and provides eight analog ports. MX8A supports the following types of configuration.

Table 1-6 Configuration Combination of MX8A

Models	Number of FXS Ports	Number of FXO Ports
MX8A-4S/4	4	4
MX8A-8S	8	0
MX8A-8FXO	0	8

Table 1-7 Voice Interface Cards Supported by the MX8A

Voice Interface Card Types	Number of FXS Ports	Number of FXO Ports
401A-4FXS	4	0
401A-4FXO	0	4
401A-2FXS/2FXO	2	2

Figure 1-3 MX8A Front Panel

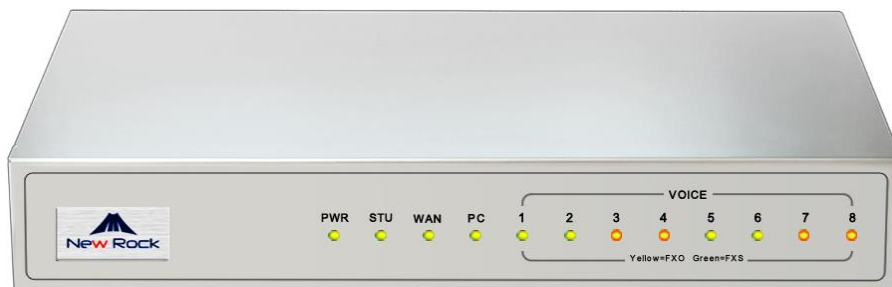

Table 1-8 Description of MX8A Front Panel

Item	Description
PWR	Power indicator
STU	Status indicator
WAN	WAN interface indicator
PC	PC interface indicator
VOICE	FXS/FXO port indicator

Figure 1-4 MX8A Back Panel

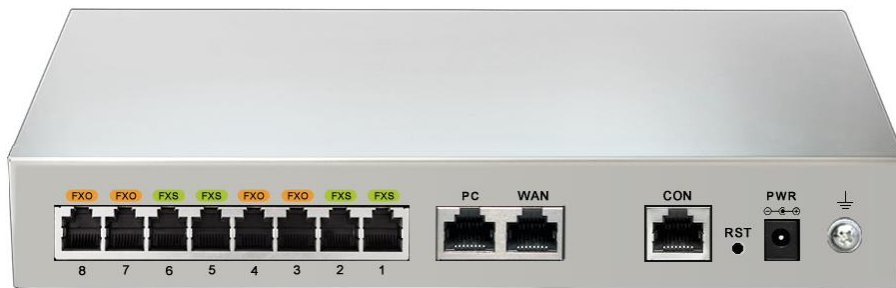

Table 1-9 Description of MX8A Back Panel

Item	Description
CON	The console port is used for local management and testing. PCs can be connected to device by linking the RS232 port to CON port. Connecting cables need to be produced or purchased. If the connection is established between the device and the mobile PC with no RS232 ports, please use the cable together with a USB to an RS232 converter cable. Cables are shown below in Figure 1-5 and Figure 1-6.
PC/WAN	The PC port is used to connect a computer. The WAN port is used to connect the uplink network. Both are 10/100 Mbps Ethernet ports (RJ45). They share one IP address, which, by default, is obtained through DHCP. If no IP address is obtained, 192.168.2.218 is used by default, and you can change it on Basic > Network page.
FXO/FXS	FXS port or FXO port

Figure 1-5 RJ45 to RS232 Serial Cable



Figure 1-6 USB to RS232 Converter Cable



Table 1-10 Indicator Status of MX8A

Indicator	Status	Description
PWR (green)	Blinking green	The device is starting.
	Steady green	The device is running.
	Off	The device is powered off or a power supply fault occurred.
STU (red, green)	Steady red	The WAN interface failed to acquire the IP address. Possibly the WAN interface is not connected to a network cable, the WAN interface

Indicator	Status	Description
		address fails to be acquired by DHCP, the IP addresses are conflicted, and the PPPoE dialing fails.
	Blinking red	The device is starting or the KUPDATE is upgrading.
	Steady green	Registration is successful.
	Blinking alternatively between red and green	Registration failed.
	Blinking green	Calling.
	Off	Registration has not started.
WAN (green)	Steady green	A WAN connection is established without any service flow.
	Blinking green	A WAN connection is established with service flow.
	Off	WAN interface is disconnected.
PC (green)	Steady green	A link is connected without any service flow.
	Blinking green	A service flow is being transmitted.
	Off	A link is not connected.
VOICE (Green-FXS, yellow-FXO)	Indicates line type and device status:	
	Blinking yellow	The device is starting and the port is an FXO port.
	Blinking green	The device is starting and the port is an FXS port.
	Off	No line is detected. Possibly the voice interface card is not inserted or the port is damaged.
	Indicates running status:	
	Steady yellow	Calling in or out via an analog trunk.
	Blinking yellow	Ringling of calling in for an analog trunk.
	Steady green	Off-hook or call established
	Blinking green	Ringling on incoming call
	Off	The port is in idle status
	Note: The device starts up for approximate 30s to indicate line type, then indicates running status.	
Indicator of button:		
RST	To restore the MX8A to factory default, press the RST for more than 3 seconds and release it when the STU light starts blinking in red. This setting will be valid after rebooting the device.	

1.3.3 MX60

Designed with a 1U high and 19 inch wide compact chassis, MX60 is suitable for installation in a standard cabinet. MX60 has a built-in power module with the rating voltage of 100-240 V AC or -48 V DC (DC is optional). The interface card of MX60 uses a RJ-45 socket and is connected to the distribution panel in equipment room using CAT-5 cables supplied with the unit. MX60 offers up to 48 interfaces of FXS/FXO. MX60 supports the following types of configuration.



Table 1-11 Configuration Combination of MX60

Models	Number of FXS Ports	Number of FXO Ports
MX60-16S	16	0
MX60-32S	32	0
MX60-48S	48	0
MX60-16FXO	0	16
MX60-32FXO	0	32
MX60-48FXO	0	48
MX60-8S/8	8	8
MX60-24S/8	24	8
MX60-40S/8	40	8
MX60-16S/16	16	16
MX60-32S/16	32	16
MX60-24S/24	24	24

Figure 1-7 MX60 Front Panel



Table 1-12 Description of MX60 Front Panel

Item	Description
	Three interface slots; each can correspond with four RJ45 sockets; each RJ45 socket can correspond with four pairs of analog lines. Note: Numbers of interface slots vary from different configuration.
	Matrix of 4 x 4 LED status indicators on interface card.

Each RJ45 socket has 8 pins leading out 4 pairs of analog telephone or trunk lines in agreement with the pair specifications for Ethernet interfaces, whose corresponding relations can be seen in the table below. CAT-5 cables are used to connect the interface card and distribution panel in equipment installation. Standard RJ11 telephone lines can be used to plug in a RJ45 socket. The telephone/trunk lines are connected to the 3rd pair of pins for simple call test.

Table 1-13 Pin Specifications for MX60 RJ45 Socket Port

RJ45 Pin Number	1	2	3	4	5	6	7	8
Analog line pair	1 st Pair		2 nd Pair	3 rd Pair		2 nd Pair	4 th Pair	
	TIP1	RING1	TIP2	TIP3	RING3	RING2	TIP4	RING4
Reference color	Orange white	Orange	Green white	Blue	Blue white	Green	Brown white	Brown

Figure 1-8 Schematic Diagram of MX60 Subscriber Line Connection

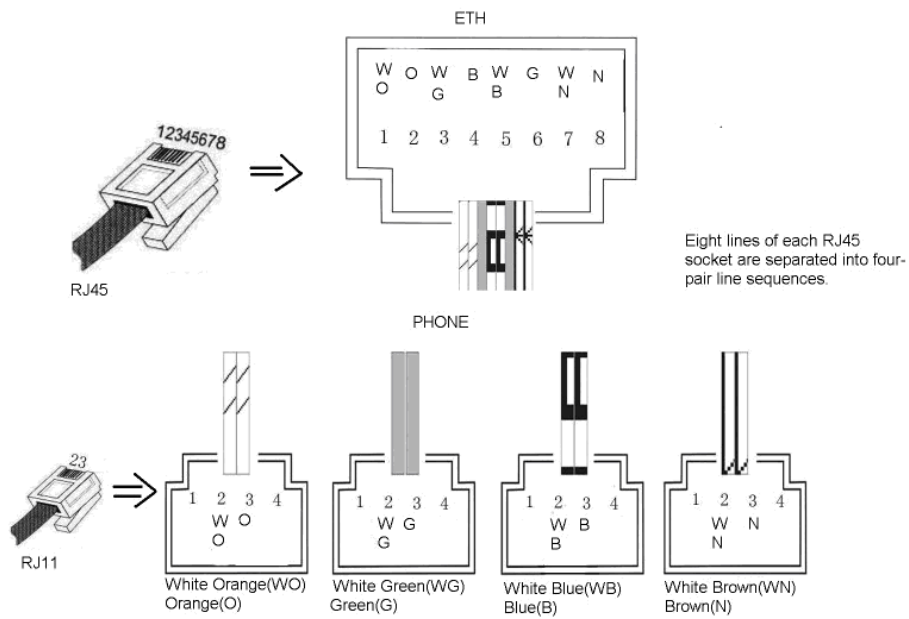

Figure 1-9 MX60 Back Panel-AC



Figure 1-10 MX60 Back Panel-DC



Table 1-14 Description of MX60 Back Panel





Item	Description
	Ground Pole
PWR/STU/ALM	Indicator, see Table 1-15 for description
USB	USB interface
CON	Configuration interface (CON), Ethernet lines used for local management and debugging
ETH1/ETH2	Two 10/100 Mbps Ethernet ports (RJ45). They share one IP address, which by default is 192.168.2.240, and you can change it on Basic > Network page.
	Cooling fan
	AC power socket, 100-240 VAC voltage input.
	DC power socket, -48 VDC input.

Table 1-15 Meanings of MX60 Indicators

Mark	Function	Status	Description
PWR	Power Indication	Green	Power on
		Off	Power off
STU	Status Indication	Off	System locked and inactive
		Blinking green	Normal operation
ALM	Alarm Indication	Off	No alarms
		Blinking red	New alarms occurred but not confirmed.
		Steady Red	System in the process of powered up and not in the normal operation mode
		Red	Alarms existed and all alarm information confirmed.

1.3.4 MX120

The device of MX120 can hold four interface cards which enable to flexibly configure FXS and FXO ports. And each card equips up to 24 ports. MX120 can provide up to 96 ports. It supports the following configurations:

Table 1-16 MX120 Interface Card

Type	FXS Ports	FXO Ports
24FXS	24	0
24FXO	0	24
16FXS/8	16	8
12FXS/12	12	12



Table 1-17 Configuration Combination of MX120

Models	Number of FXS Ports	Number of FXO Ports	Concurrent calls
MX120-NA-C-2U	Depend on the models and number of the interface cards.		24
MX120-NA-D-2U			48
MX120-NA-E-2U			72
MX120-NA-F-2U			96

Figure 1-11 MX120 Front Panel



Table 1-18 Description of MX120 Front Panel

Item	Description
	Matrix of 6x4 LED status indicator on interface card
	Four interface slots; each can contain one 24-port interface card. Note: The interface card is not hot swappable!



Note

Do not plug and remove the interface cards of MX120 when equipment is powered on.

Numbering definition of system interface slots: on the low-left side of chassis is #1 slot (marked with No.1 to 24), on the low-right side of chassis is #2 slot (marked with No.25 to 48), on the up-left side of chassis is #3 slot (marked with No.49 to 72), and on the up-right side of chassis is #4 slot (marked with No.73 to 96).

Each RJ45 socket has 8 pins leading out 4 pairs of analog telephone or trunk lines in agreement with the pair specifications for Ethernet interfaces, whose corresponding relations can be seen in the table below. CAT-5 cables are used to connect the interface card and distribution panel in equipment installation. Standard RJ11 telephone lines can be used to plug in a RJ45 socket. The telephone/trunk lines are connected to the 3rd pair of pins for simple call test.

Table 1-19 Pin Specifications for MX120 RJ45 Socket Port

RJ45 Pin Number	1	2	3	4	5	6	7	8
Analog line pair	1 st Pair		2 nd Pair	3 rd Pair		2 nd Pair	4 th Pair	
	TIP1	RING1	TIP2	TIP3	RING3	RING2	TIP4	RING4
Reference color	Orange white	Orange	Green white	Blue	Blue white	Green	Brown white	Brown

Figure 1-12 Schematic Diagram of MX120 Subscriber Line Connection

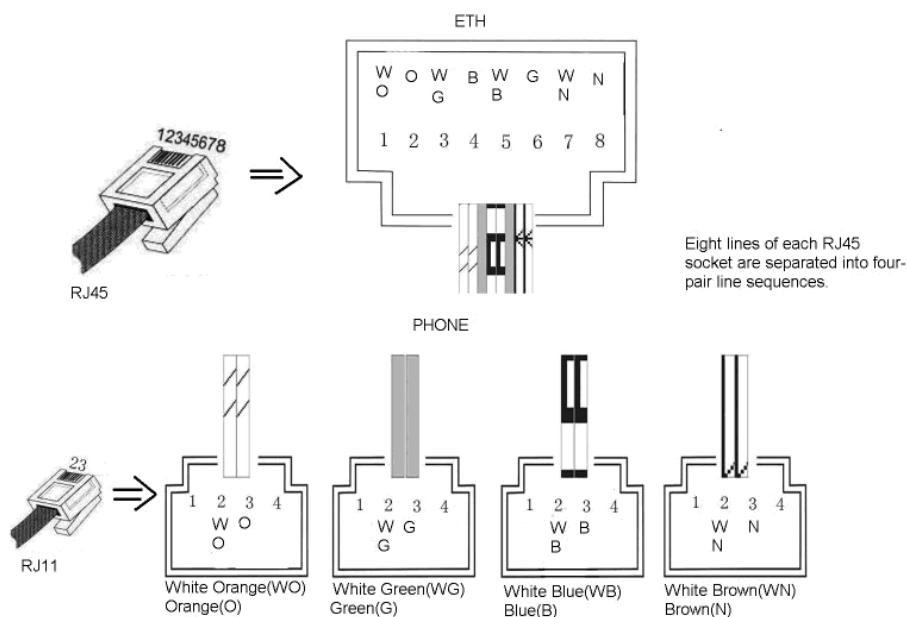

Table 1-20 Corresponding Relation Between MX120 RJ45 Socket and Line Number

RJ45 Socket No. (From Left to Right)	1	2	3	4	5	6
Line No. of This Card	1 ~ 4	5 ~ 8	9 ~ 12	13 ~ 16	17 ~ 20	21 ~ 24

There is a 6 × 4 LED indicator matrixes on the left side of interface board. Each row of LED indicator matrixes matches four telephone lines on a RJ45. The first row on the left matches Line 1-4 respectively from top to bottom, the first row on the right matches Line 21-24 respectively from top to bottom, and the middle rows in the same manner.

LED indicators are used for multiple purposes as follows:

- Line status indication: this is the most common mode during normal use of equipment. In this mode, if a line is idle, the indicator corresponding to it goes off; if a line is in call or in use status (such as ringing, offhook) the indicator corresponding to it goes on.
- Line type indication: this is the mode for cable wiring check when installing the equipment. This mode can be entered by disconnecting Ethernet cables (Both WAN and LAN ports must be disconnected) at installation stage. After entering this mode, steady on LED indicates that the corresponding line is equipped as analog subscriber line type, blinking LED indicates that the corresponding line is equipped as analog trunk line type, off LED indicates that the corresponding line is not equipped or not ready for use.
- System operation status indication: this is the mode for displaying information on system operation of equipment in specific conditions. Usually, this mode is entered when some prompts are required to give operator during equipment startup, diagnosis or operation. In this mode, LED flashes to display numbers, letters or other patterns in matrix. Please refer to Table 1-23.

Figure 1-13 MX120 Back Panel-AC



Figure 1-14 MX120 Back Panel-DC



Table 1-21 MX120 Back Panel





Item	Description
PWR/STU/ALM	Indicator, see Table 1-22 for description.
USB	USB interface
CON	Configuration interface (CON), used for local management and debugging.
	Ground Pole
ETH1/ETH2	Two 10/100 Mbps Ethernet ports (RJ45). They share one IP address, which by default is 192.168.2.240 and you can change it on Basic > Network page.
	Cooling fan
	AC power socket, 100-240 VAC voltage input.
	DC power socket, -48 VDC input.

Table 1-22 Meanings of MX120 Indicators

Mark	Function	Status	Description
PWR	Power Indication	Green	Power on
		Off	Power off
STU	Status Indication	Off	System locked and inactive
		Blinking green	Normal operation
ALM	Alarm Indication	Green	No alarms
		Blinking red	New alarms occurred but not confirmed
		Steady red	Power-on is in progress; awaiting normal operation
		Red	Alarms existed and all alarm information confirmed

Table 1-23 MX120 System Operation State

Glittery letter	Status meaning
C	The IP address of gateway conflicts with that of other equipment in LAN. Please settle this problem before the gateway can be operated normally.

Glittery letter	Status meaning
D	Internal failures have been encountered during gateway start up procedure. Please contact your local distributor for further diagnosis.
P	The gateway is in progress of system software upgrade. Please guarantee stable power supply and do not conduct other operations during this period.
T	The application software of gateway has been exited. If it cannot be restored by rebooting the system, please contact your local distributor for further diagnosis.

1.3.5 MX120G

Designed with a 2U high and 19 inch wide compact chassis, MX120G is suitable for installation in a standard cabinet.

The interface card of MX120G uses a RJ-45 socket and is connected to the distribution panel in equipment room using CAT-5 cables supplied with the unit.

The device of MX120G can hold four interface cards to flexibly configure FXS and FXO ports. And each card equips 24 ports. MX120G can provide up to 96 ports. It supports the following configurations:

Table 1-24 MX120G Interface Card

Type	FXS Ports	FXO Ports
24FXS	24	0
24FXO	0	24
16FXS/8	16	8
12FXS/12	12	12

Table 1-25 Configuration Combination of MX120G

Models	Number of FXS Ports	Number of FXO Ports	Concurrent calls	Description
MX120G-NA-X	Depend on the models and number of the interface cards.		Depend on the value of X. X=C, it is 24 X=D, it is 48 X=E, it is 72 X=F, it is 96	Single AC power
MX120G-NA-X-2AC				Dual AC power
MX120G-NA-X-1DC				Single DC power
MX120G-NA-X-2DC				Dual DC power

Figure 1-15 MX120G Front Panel



Table 1-26 Description of MX120G Front Panel

Item	Description
	Matrix of 6x4 LED status indicator on interface card

Item	Description
SLOT1~4	Four interface slots; each can contain one 24-port interface card. Note: The interface card is hot swappable, but you should reboot the device after the replacement of the interface card!

Numbering definition of system interface slots: on the low-left side of chassis is #1 slot (marked with No.1 to 24), on the low-right side of chassis is #2 slot (marked with No.25 to 48), on the up-left side of chassis is #3 slot (marked with No.49 to 72), and on the up-right side of chassis is #4 slot (marked with No.73 to 96).

Each RJ45 socket has 8 pins leading out 4 pairs of analog telephone or trunk lines in agreement with the pair specifications for Ethernet interfaces, whose corresponding relations can be seen in the table below. CAT-5 cables are used to connect the interface card and distribution panel in equipment installation. Standard RJ11 telephone lines can be used to plug in a RJ45 socket. The telephone/trunk lines are connected to the 3rd pair of pins for simple call test.

Table 1-27 Pin Specifications for MX120G RJ45 Socket Port

RJ45 Pin Number	1	2	3	4	5	6	7	8
Analog line pair	1 st Pair		2 nd Pair	3 rd Pair		2 nd Pair	4 th Pair	
	TIP1	RING1	TIP2	TIP3	RING3	RING2	TIP4	RING4
Reference color	Orange white	Orange	Green white	Blue	Blue white	Green	Brown white	Brown

Figure 1-16 Schematic Diagram of MX120G Subscriber Line Connection

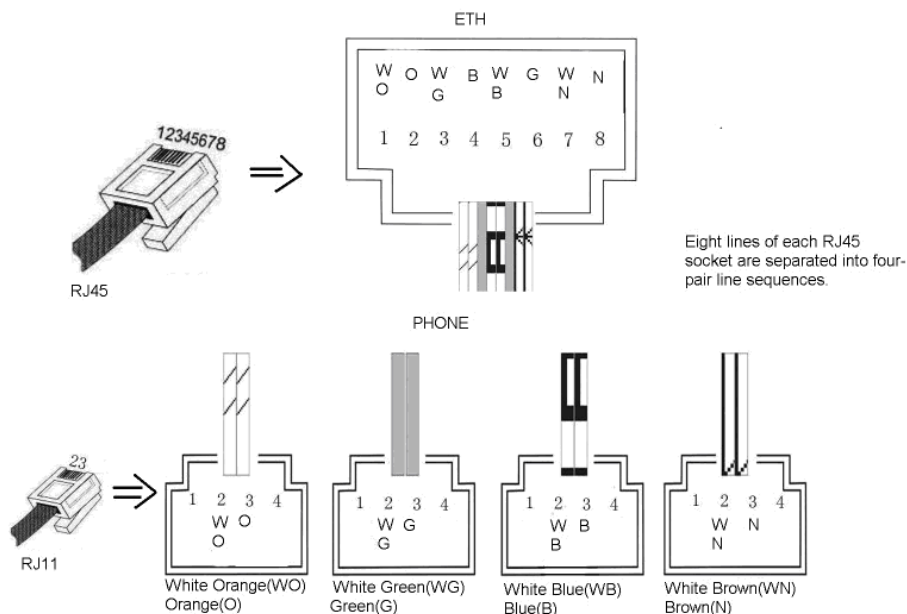

Table 1-28 Corresponding Relation Between MX120G RJ45 Socket and Line Number

RJ45 Socket No. (From Left to Right)	1	2	3	4	5	6
Line No. of This Card	1 ~ 4	5 ~ 8	9 ~ 12	13 ~ 16	17 ~ 20	21 ~ 24

There is a 6 × 4 LED indicator matrixes on the left side of interface board. Each row of LED indicator matrixes matches four telephone lines on a RJ45. The first row on the left matches Line 1-4 respectively from top to bottom, the first row on the right matches Line 21-24 respectively from top to bottom, and the middle rows in the same manner.

LED indicators are used for multiple purposes as follows:

- Line status indication: this is the most common mode during normal use of equipment. In this mode, if a line is idle, the indicator corresponding to it goes off; if a line is in call or in use status (such as ringing, offhook) the indicator corresponding to it goes on.
- Line type indication: this is the mode for cable wiring check when installing the equipment. This mode can be entered by disconnecting Ethernet cables (Both WAN and LAN ports must be disconnected) at installation stage. After entering this mode, steady on LED indicates that the corresponding line is equipped as analog subscriber line type, blinking LED indicates that the corresponding line is equipped as analog trunk line type, off LED indicates that the corresponding line is not equipped or not ready for use.
- System operation status indication: this is the mode for displaying information on system operation of equipment in specific conditions. Usually, this mode is entered when some prompts are required to give operator during equipment startup, diagnosis or operation. In this mode, LED flashes to display numbers, letters or other patterns in matrix. Please refer to Table 1-31.

Figure 1-17 MX120G Back Panel-AC



Figure 1-18 MX120G Back Panel-DC



Table 1-29 MX120G Back Panel



Item	Description
RST	To restore the device to factory default, press the RST for more than 3 seconds and release it when the STU light starts blinking in red. This setting will be valid after rebooting the device.
CON	Configuration interface (CON), used for local management and debugging.
ETH1/ETH2	Two 10/100 Mbps Ethernet ports (RJ45). They share one IP address, which by default is 192.168.2.240 and you can change it on Basic > Network page.
USB	USB interface
	AC power socket, 100-240 VAC voltage input.
	DC power socket, -48 VDC input.
	Ground Pole

Table 1-30 Meanings of MX120G Indicators

Indicator	Status	Description
PWR (red, green)	Steady green	The power supply is working.
	Off	No power supply.
	Steady red	The power supply is abnormal.
STU (red, green)	Blinking green	The device is running.
	Steady red	The device is starting.
	Blinking red	The device is under diagnosis.
	Off	The device is locked.
ALM (red, green)	Off	No alarm
	Blinking red	The alarms indicated by the blinking alphabetic messages C/E/T on LED dot-matrix are generated.
	Steady red	The alarms indicated by the blinking alphabetic messages D on LED dot-matrix are generated.
ETH1/ETH2 (green)	Steady green (right side)	The transmission rate is 1000 Mbps.
	Off (right side)	The transmission rate is 10/100 Mbps.
	Steady green (left side)	A physical connection is established without any traffic.
	Blinking green (left side)	A physical connection is established with traffic.
	Off (left side)	No connection is established.
USB (green)	Steady green	The USB device is detected.
	Off	The USB device is not detected.

Table 1-31 MX120G System Operation State

Glittery letter	Status meaning
Blinking with C	IP address conflicts
Blinking with D	The severe starting failure needs to address by your dealer
Blinking with E	Network failure
Blinking with P	Software upgrading
Blinking with T	App exited (The device cannot be used normally)

2 Parameters Setting

2.1 Login

2.1.1 Obtaining Gateway IP Address

MX8A/HX4E Gateways start DHCP service by default, and automatically obtain an IP address on the LAN; you can use the factory-default gateway IP address if it is unable to be obtained (e.g. when connected directly with a computer).

By default, the MX60/MX120/MX120G uses a static IP address.

To change the fixed IP address, you can use a telephone connected to the FXS port and dial ***90+the fixed IP address+#subnet mask#IP address of the gateway#0#**. The dots "." in the IP address need to be replaced with star keys "*".

To obtain an IP address through DHCP, you can use a telephone connecting to the FXS port and dial ***90###1#**. After "The feature is now activated" is heard, restart the device.

Table 2-1 Default IP Address of Gateway

Type	Default DHCP Service	Default IP Address	Default Subnet Mask
MX8A	Enabled	192.168.2.218	255.255.0.0
HX4E	Enabled	192.168.2.218	255.255.0.0
MX60	Disabled	192.168.2.240	255.255.0.0
MX120	Disabled	192.168.2.240	255.255.0.0
MX120G	Disabled	192.168.2.240	255.255.0.0

- You can dial ## to obtain the current gateway IP address, version information of firmware and port used to access the Web GUI using the telephone connected to the subscriber line (FXS ports) after the equipment is powered on.
- If the device does not have FXS ports (such as an MX8A-8FXO or HX440E), you can use New Rock's device IP address obtaining tool called "Finder" to obtain the IP address. You can download the "Finder" software on "Files" page of http://www.newrocktech.com/ViewProduct_E.asp?id=68
- A user could fail to log in with the default IP address if the IP address of user's computer and the default gateway IP address are not at the same network segment. Set the IP address of user's computer to be identical with the same network segment of the gateway. For example, if the gateway IP address is 192.168.2.218, set the computer's IP address to any address at the network segment of 192.168.2.XXX.

2.1.2 Logging On

Enter the gateway IP address in the browser address bar (e.g. 192.168.2.218). You can enter the gateway configuration login interface by entering a password on the login interface. Both Chinese and English are

provided for the Web GUI.



Note

- The Web GUI can be accessed using browsers such as Internet Explorer 8 to 11, Firefox, and Google Chrome. The IE browser is used as an example below.
- The HX4E/MX8A is only allowed to access using HTTPS. Since the factory default certificate is used a prompt like "There is a problem with this website's security certificate" may occur. Click **Continue to this website** to access the login page.

Figure 2-19 Login Interface for MX8A Gateway Configuration



2.1.3 Gateway Administrator and Operator Rights

Login users are classified into administrator and operator. The default password is shown in Table 2-2. The password is shown in a cipher for safety.

Table 2-2 Default Passwords of Gateway

Type	Default Administrator Passwords (lowercase letters required)	Default Operator Password
MX8A	mx8	operator
HX4E	hx4	operator
MX60	mx60	operator
MX120	mx120	operator
MX120G	mx120	operator

The administrator is allowed to browse and modify any configuration parameter and modify login passwords. After login, "Welcome admin" is displayed on the upper left corner of the interface.

The operator is allowed to browse a subset of the configuration parameters.

The following pages are not allowed to visit:

Advanced > Security

System tool > Change password

System tool > Software upgrade

System tool > Import data

System tool > Export data

After login, "Welcome user" is displayed on the upper left corner of the interface.

The gateways allow multiple users to log in if needed.

- When multiple administrators log in, the first can modify, while others may only browse.



Note

- The system will confirm timeout if users do not conduct any operation within 10 minutes after login. They are required to log in again for continuing operations.
- Upon completion of configuration, click the **Logout** button to return to the login page, so as not to affect the login permission of other users.
- To ensure system security, please choose **Tools > Change password** and change the password when you log in for the first time. For details, see 2.10.1 Change Password.

2.2 Buttons Used on Gateway Management Interface

A **save** button is at the bottom of each configuration interface. It is used to submit configuration information. Users should click the **Save** button after the completion of parameter configuration on a page. A success prompt will appear if configuration information is accepted by the system; if **The configuration takes effect after the system is restarted** dialog box appears, it means that the parameters are valid only after a system restart. It is recommended that users press the **Reboot** button on the top right corner to enable the configuration after changing all parameters to be modified.

2.3 Basic Configuration

2.3.1 Status

After login, open the **Basic** tab page to view device information. If the SIP port of the device is 5060, you are advised to modify it.

Figure 2-20 Status Interface

Basic	Line	Trunk	Routing	Advanced	Call Status	Logs	Tools
<u>Status</u>	Network	VLAN	System	SIP	MGCP	FoIP	
Local signaling port	5060			It is not recommended to use port 5060 to avoid SIP DoS attack. Click here to change it.			
Host name	MX8-II						
MAC address	00:0E:A9:39:03:2B						
Model	MX8A-4S/4						
IP address	192.168.2.218						
SNTP				The synchronization failed Configuration			
System up time	1 hour 42 minutes 36 seconds						

2.3.2 Network

After login, click **Basic > Network** to open the configuration interface.

Figure 2-21 Network Configuration Interface

Basic	Line	Trunk	Routing	Advanced	Call Status	Logs	Tools
Status	<u>Network</u>	VLAN	System	SIP	MGCP	FoIP	
Setup	Obtain an IP address automati						
IP address	192.168.120.59						
Subnet mask	255.255.255.0						
Default gateway	192.168.120.1						
DNS server	<input checked="" type="radio"/> Obtained automatically <input type="radio"/> Specified manually						
STUN							
STUN	<input type="radio"/> Enable <input checked="" type="radio"/> Disable						
Save							

Table 2-3 Network Configuration Parameters

Name	Description
Setup	Methods for obtaining an IP address. <ul style="list-style-type: none"> • Static IP address: static IP address is used; • Obtain an IP address automatically: use the dynamic host configuration protocol (DHCP) to obtain IP addresses and other network parameters; • PPPoE: PPPoE service is used.
Username	Enter an authentication user name if PPPoE service is selected, and there is no default value.
Password	Enter an authentication password if PPPoE service is selected, and there is no default value.
IP address	If “Static IP” or “DHCP” is selected but an address fails to be obtained, the gateways will use the IP address filled in here. If the gateways obtain an IP address through DHCP, the system will display the current IP address automatically obtained from DHCP.
Subnet mask	The subnet mask is used with an IP address. When the gateway uses a static IP address, this parameter must be entered; when an IP address is automatically obtained through DHCP, the system will display the subnet mask automatically obtained by DHCP. It has no default value.

Name	Description
Default gateway	The IP address of LAN gateway. When the gateway obtains an IP address through DHCP, the system will display the LAN gateway address automatically obtained through DHCP. It has no default value.
DNS server	Obtained automatically: When the connection mode is "DHCP" or "PPPoE", the device uses the automatically obtained IP address of the DNS server. Specified manually: Use the DNS server addresses specified manually.
Primary DNS Server	If Specified manually is selected, the network IP address of the Primary DNS server must be entered, there is no default value.
Secondary DNS Server	If Specified manually is selected, the network IP address of the Secondary DNS server can be entered, there is no default value.
STUN	The device periodically sends a STUN request to the STUN server to obtain the public IP address for the front-end router. It is disabled by default.
Server IP address / Name	Set the IP address or domain name of the STUN server. The factory default STUN server is the New Rock STUN server.
Server port	Set the port of STUN server. It is 3478 by default.
Session interval	The interval at which the device sends a STUN request ranges from 30 to 3600 seconds. It is 60 second by default.
Operations	<ul style="list-style-type: none"> • Trunk re-registration: A re-registration of the SIP trunk is triggered upon the detection of the change of the public IP address of the device by using STUN query. Normally, the session interval of STUN request should be shorter than the registration period. Note: The IP address obtained through STUN is used only for re-registration of SIP server, and it is not used in SIP message fields such as Via and Contact and SDP C field. • Trunk re-registration & NAT address updating: A re-registration of the SIP trunk is triggered upon the detection of the change of the public IP address of the device by using STUN query. The IP address obtained through STUN is used in SIP message fields such as Via and Contact and SDP C field.

2.3.3 VLAN

After login, click **Basic** > **VLAN** to open the configuration interface.

Figure 2-22 VLAN Configuration Interface

The screenshot shows the 'Basic' configuration tab for a VLAN. It is divided into two main sections: 'Automatic discovery' and 'Manual configuration'.
Automatic discovery:
 - LLDP: On Off
 - LLDP packet interval: 30 s (Range: 5 - 3600)
 - DHCP: On Off
Manual configuration:
 - Activate: On Off
 - Mode: Single VLAN Multi-service VLAN
 - VLAN tag: 0 (Range: 3 - 4093)
 - VLAN QoS: 0 (Best effort)
 - IP address assignment: Static
 - IP address: 192 . 168 . 2 . 218
 - Netmask: 255 . 255 . 0 . 0
 - Gateway IP address: 192 . 168 . 2 . 1
 - MTU: 1500 (Range: 576 - 1500)
 A 'Save' button is located at the bottom right of the configuration area.

Table 2-4 VLAN Configuration Parameters

Name	Description
Automatic discovery	
LLDP	<ul style="list-style-type: none"> • On: Indicates that the LLDP is enabled. The device periodically sends LLDP messages and parses received LLDP messages to get VLAN ID and priority. • Off (default value): Indicates that the LLDP is disabled. The device does not send any LLDP messages, nor parses any received LLDP messages.
LLDP Packet interval	This parameter specifies the interval at which LLDP messages are sent after the LLDP is enabled. The value range is 5 to 3600 seconds. The default value is 30 seconds.
DHCP	Enable the device to obtain the VLAN tag and QoS by using DHCP option 132 and option 133. Note: This function works only when DHCP is selected on Basic > Network page.
Manual configuration	
Activate	Enable/disable VLAN.
Mode	Select the VLAN mode: <ul style="list-style-type: none"> • Single VLAN: All services of the device are on the same VLAN, and the device receives only data packets carrying the VLAN and includes the VLAN tag in all sent data packets. • Multi-service VLAN: The device can configure different VLAN information for the voice service (SIP signaling and RTP/T.38 media stream) and the management service (HTTP/HTTPS, Telnet) and includes a different VLAN tag in a data packet of a different service.

Name	Description
Voice VLAN	VLAN to which the voice service (SIP signaling and RTP/T.38 media stream) belongs. <ul style="list-style-type: none"> • None: disable the voice VLAN • Mode 1: SIP and RTP/T.38 are on the same VLAN • Mode 2: SIP and RTP/T.38 are on different VLANs
Management VLAN	<ul style="list-style-type: none"> • Selected: enable the management VLAN • Deselected: disable the management VLAN
VLAN tag	Tag of the VLAN. The value ranges from 3 to 4093.
VLAN QoS	Priority of the VLAN. The value ranges from 0 to 7. A larger value indicates a higher priority of a to-be-sent data packet.
IP address assignment	Type for obtaining the IP address of the VLAN interface. <ul style="list-style-type: none"> • Static: set the IP address to a static IP address • DHCP: automatically obtain an IP address by using the DHCP protocol
IP address	IP address of the VLAN interface
Netmask	Subnet mask of the VLAN interface
Gateway IP address	IP address of the gateway of the VLAN interface
MTU	Maximum Transmission Unit value of the VLAN interface. The value ranges from 576 to 1500. The default value is 1500.

**Note**

- A reboot is required to enable the VLAN configuration.
- After a VLAN is configured, only PCs in the same VLAN can access the device.
- The device address used to log in to the Web GUI can be obtained by connecting a phone to an FXS port of the device, and dialing ##. In the case of a single VLAN, the IP address of the single VLAN is voiced; in the case of a multi-service VLAN, the IP address of the management VLAN is voiced.

2.3.4 System

After login, click **Basic** > **System** to open the configuration interface.

Figure 2-23 System Configuration Interface

The screenshot shows a web-based configuration interface for a voice gateway. At the top, there are tabs for 'Basic', 'Line', 'Trunk', 'Routing', 'Advanced', 'Call Status', 'Logs', and 'Tools'. Below these, there are sub-tabs for 'Status', 'Network', 'VLAN', 'System', 'SIP', 'MGCP', and 'FoIP'. The 'System' tab is active. The main area contains several configuration fields:

- Off-hook timer: 15 s (Range: 2 - 60, Default: 15)
- Interdigit timer: 5 s (Range: 2 - 60, Default: 5)
- Complete entry timer: 2 s (Range: 1 - 10, Default: 2)
- Codec: G.729A/20, G.711U/20, G.711A/2 (Range: G.729A/20,G.711U/20,G.711A/2)
- Hook-flash handle: Internal (dropdown menu)
- DTMF transmission method: RFC 2833 (dropdown menu)
- RFC 2833 payload type: 101 (Range: 96 to 127, Default: 101, consistent with the opposite end (such as: softswitch platform))
- DTMF tone duration: 100 ms (Range: 50 - 150, Default: 100)
- DTMF interdigit pause: 100 ms (Range: 50 - 150, Default: 100)
- Min. DTMF detection duration: 48 ms (The range must be 32 to 96 in multiples of 16)
- DTMF detection duration increment against talk-off: 16 ms

A 'Save' button is located at the bottom right of the configuration area.

Table 2-5 System Configuration Parameters

Name	Description
Off-hook timer	If a subscriber does not dial any digit within the specified time by this parameter after off-hook, the gateways will prompt to hang up with a busy tone. The value must be an integer, decimal points are not allowed. Unit: Seconds; Default value: 15 seconds.
Interdigit timer	The maximum time interval to dial the next digit. After timeout, the gateways will call out with the collected number. The value must be an integer, decimal points are not allowed. Unit: Seconds; Default value: 5 seconds.
Complete entry timer	The value must be an integer, decimal points are not allowed. Unit: Seconds; Default value: 2 seconds. This parameter is used with the "x.T" rule set in dialing rules. For example, there is "021.T" in the dialing rules table. When a subscriber has dialed 021 and has not dialed the next number within a set time by this parameter (e.g. 2 seconds), the gateways will consider that the subscriber has ended dial-up and call out the dialed number 021.
Codec	Codecs supported by the device include G729A/20, PCMU/20 and PCMA/20. This parameter must be set due to no default value. For details, see Table 2-6. Several encoding methods can be configured in this item at the same time, separated with "," in the middle; the gateways will negotiate with the platform in the order from front to back when configuring the codec methods.
Hook-flash handle	The gateways provide the following processing modes after detecting hook flash from subscriber terminals: Internal: the hook flash event will be handled internally; Server(RFC 2833): transmitting the hook flash to platform with RFC 2833; Server (SIP INFO): transmitting the flash-off to platform with SIP INFO.

Name	Description
DTMF transmission method	<p>Transmission modes of DTMF signal supported by the gateways include RFC 2833, Audio and SIP INFO. The factory default value is RFC 2833.</p> <ul style="list-style-type: none"> • RFC 2833: separate DTMF signal from sessions and transmit it to the platform through RTP data package in the format of RFC2833; • Audio: transmit DTMF signal to the platform with sessions; • SIP INFO: separate DTMF signal from sessions and transmits it to the platform in the form of SIP INFO messages. • RFC2833+SIP INFO: send DTMF signals simultaneously via RFC 2833 and SIP INFO.
RFC 2833 payload type	Used with "RFC 2833" in the DTMF transmission modes. The default value of 2833 payload type is 101. The effective range available: 96 ~ 127. This parameter should match the setting of far-end device (e.g. platform).
DTMF tone duration	This parameter sets the on time (in ms) of DTMF signal sent from FXO port. The default value is 100 ms. The duration time range is 50 ~ 150 ms.
DTMF interdigit pause	This parameter sets the off time (ms) of DTMF signal sent from port. The default value is 100 ms. The duration time range is 50 ~ 150 ms.
Min. DTMF detection duration	Minimum duration time of effective DTMF signal. Its effective range is 32 to 96 ms. The default value is 48 ms. The greater the value is set, the more stringent the detection.
DTMF detection duration increment against talk-off	<p>An actual detection threshold is determined by combining the Min. DTMF detection duration and this parameter.</p> <p>Actual detection threshold = Min. DTMF detection duration + DTMF detection duration increment against talk-off.</p> <p>The valid values are 16, 32, and 48 in million seconds. Increase the value can prevent false detection of DTMF signal.</p>

Table 2-6 Codec Methods Supported by Gateways

Codec	Bit Rate (Kbit/s)	Time Intervals of RTP Package Sending (ms)
G729A	8	10/20/30/40
PCMU/PCMA	64	10/20/30/40

2.3.5 SIP

After login, click **Basic** > **SIP** to open the configuration interface.

Figure 2-24 SIP Configuration Interface

The screenshot shows the SIP Configuration Interface with the following fields and values:

- Local signaling port:** 5060 (Range: 1 - 9999, Default: 5060)
- Increments of port number:** No backup
- Registrar server:** (Empty field)
- Proxy server:** localhost:5060 (e.g. 168.33.134.51:5000 or www.sipproxy.com:5000)
- Subdomain name:** (Empty field)
- Registrar mode:** Per line
- User name:** (Empty field)
- Registrar password:** (Empty field)
- Registration expiration:** 600 s

High availability section:

- Mode:** Primary-Standby
- Backup SIP proxy:** (Empty field)
- Primary server heartbeat detection:**

A **Save** button is located at the bottom right of the configuration area.

Table 2-7 SIP Configuration Parameters

Name	Description
Local Signaling port	Configure the UDP port for transmitting and receiving SIP messages, with its default value 5060. Note: The signaling port number can be set in the range of 1-9999, but cannot conflict with the other port numbers used by the equipment.
Increments of port number	If "n" (ranked from 1-10) is chosen, after the failure registration of signaling port's original configuration, the variation of signaling port's change ranges from the original signaling port to the original signaling port +n". Register with the new signaling port value (signaling port +1) until it succeeds.
Registrar server	Configure the address and port number of the SIP registration server. The address and port number are separated by ":". It has no default value. The register server address can be an IP address or a domain name. e.g. 168.33.134.51:5000 or www.sipproxy.com:5000. When a domain name is used, you must activate DNS service and configure DNS server parameters on the network-configuration page.
Proxy server	Configure the IP address and port number of the SIP proxy server. The address and port number are separated by ":". It has no default value. The proxy server address can be set to an IP address or a domain name. e.g. 168.33.134.51:5000 or www.sipproxy.com:5000. When a domain name is used, you must activate DNS service and configure DNS server parameters on the network-configuration page. When a domain name is used, you can fill in a backup IP address in Backup SIP proxy server in the High Availability configuration. This allows the device to failover to the IP address if the domain name resolution service fails.
Subdomain name	This domain name will be used in INVITE messages. If it is not set here, the gateways will use the IP address or domain name of the proxy server as the user-agent domain name. It has no default value.

Name	Description
Registrar mode	<p>The gateway supports three registration schemes:</p> <ul style="list-style-type: none"> • Per line (default): authenticate and register per line. • Per gateway: authenticate and register per gateway. • Per line/GW auth: Enable registration per line. Use the number configuration per line. Use the global account and password in authentication.
User name	<p>Configure the user name as part of the account for registration. It has no default value.</p> <p>Note: If Per gateway or Per line/GW Auth is selected for Registrar mode, the user name must be entered here. If per line is selected the user name should be set on “Line > Feature” page (Refer to 2.4.2 Subscriber Line Features).</p>
Registrar password	<p>Password as part of account information is used for authentication by platform. It has no default value. It can be formed with either numbers or characters, and is case sensitive.</p> <p>Note: If Per gateway or Per Line/GW Auth is selected for Registrar mode, the password must be entered here. If Per line is selected the password should be set on “Line > Feature” page (Refer to 2.4.2 Subscriber Line Features).</p>
Registration expiration	<p>Valid time of SIP re-registration in seconds. Its default value is 600.</p>

2.3.6 High Availability

After login, click **Basic > SIP** to open the configuration interface.

For details, see [High Availability Configuration Guide](#).

Figure 2-25 High Availability Configuration Interface

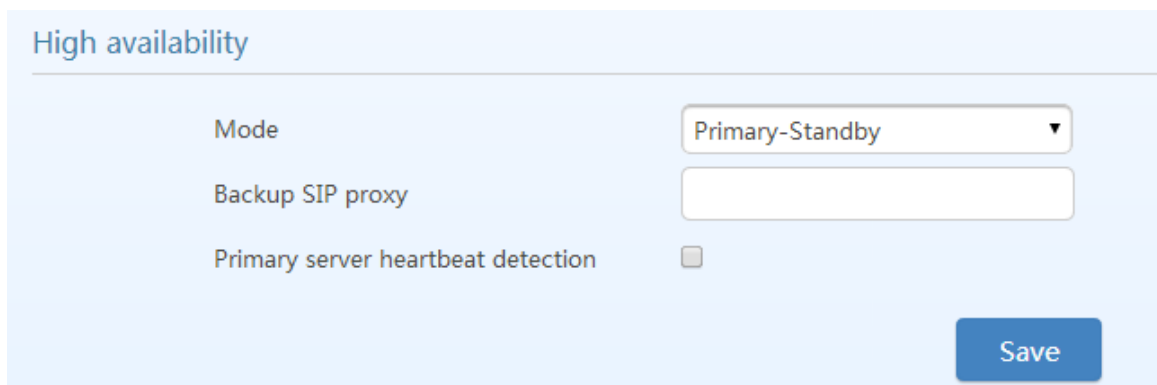

Table 2-8 Parameters

Name	Description
Mode	High availability can be configured as Primary-Standby, Active-Standby or Load Balancing mode.
Primary-Standby mode	
Backup SIP proxy	Configure the address and port number of the backup SIP proxy server. When the primary SIP server fails, the gateway failovers from the primary server to the backup server automatically.

Name	Description
Primary server heartbeat detection	Select it to send OPTIONS request to the primary SIP server all the time. If the gateway does not receive any response to OPTIONS request, it failovers to the backup server. After failover to the backup server, the gateway will still send OPTIONS to the primary server. It switches back to the primary server once the response to the OPTIONS request is received.
OPTIONS request period	The interval between receiving the response (200) from the SIP server to the previous OPTIONS and sending the next OPTIONS.
Active-Standby mode	
SIP proxy server setting	A maximum of five servers can be added.
OPTIONS Keep-alive	Enable: send OPTIONS request to the current SIP server. Disable: OPTIONS request is not sent to the current SIP server.
Active SIP server	This parameter displays the current SIP server address.
Switchover	If you click Switchover, the gateway performs switchover to the next available server in sequence based on the SIP server list.
Load Balancing mode	
SIP proxy server setting	A maximum of five SIP servers can be added.
OPTIONS request period	The interval between receiving the response (200) from the SIP server to the previous OPTIONS and sending the next OPTIONS.
OPTIONS request timeout	The period since the sending of the last OPTIONS with no response by the SIP server.
REGISTER request timeout	The period of time from the sending of the first REGISTER with no response by the previous SIP server to the sending of REGISTER to the next SIP server.

2.3.7 MGCP

The gateways use SIP protocol by default. When the gateways need to interface with MGCP protocol - based soft switch platform, set the relevant parameters here.

After login, click **Basic > MGCP** to open the configuration interface.

Figure 2-26 MGCP Configuration Interface

The screenshot shows a web-based configuration interface for MGCP. At the top, there are tabs for 'Basic', 'Line', 'Trunk', 'Routing', 'Advanced', 'Call Status', 'Logs', and 'Tools'. The 'Basic' tab is selected, and a sub-menu below it shows 'Status', 'Network', 'VLAN', 'System', 'SIP', 'MGCP', and 'FoIP'. The 'MGCP' sub-menu is active. The main configuration area contains several fields and options:

- Local port:** A text input field containing '2427'. To its right, it says '(Range: 1-9999, Default 2427)'.
- Proxy server:** A text input field. To its right, it says 'e.g. 46.33.136.50:2727 or www.proxy.com:2727'.
- User agent domain name:** A text input field. To its right, it says 'e.g. www.gatewaymgcp.com'.
- Default event package:** A text input field containing 'L,D,G'. To its right, it says 'Valid value: A, B, D, G, H, L, M, T. Default L, D, G'.
- Persistent line event:** A text input field containing 'L/HD,L/HU'. To its right, it says 'Default L/HD, L/HU'.
- FXO event package:** Two radio buttons: 'Line package' (unselected) and 'Handset package' (selected).
- Wildcard:** A dropdown menu showing 'Not allowed'.
- Below these are several checkboxes:
 - CR for End-of-Line
 - Enable first digit timer
 - Using notify instead of 401/402
 - Keep connection when on-hook
 - Quarantine default to loop
 - Using configured digit map
 - No name in default package

A blue 'Save' button is located at the bottom right of the configuration area.

Table 2-9 MGCP Configuration Parameters

Name	Description
Local port	Configure the UDP port for transmitting and receiving MGCP messages, the default value is 2427. Note: The signaling port number can be set in the range of 1-9999, but cannot conflict with the other port numbers used by the equipment.
Proxy server	Configure the IP address and port number of MGCP proxy server, separated by “:”. It has no default value. The address can be set to an IP address or a domain name according to the subscribers’ requirements. When a domain name is used, it is required to configure DNS server on the "Basic > Network" page. Examples of complete and effective configuration: 46.33.136.50:2727 or www.proxy.com: 2727 .
User agent domain name	The domain name associated with the call agent, it has no default value. DNS server is required to set. Example: www.gatewaymgcp.com.
Default event package	List all the types of default event packages supported by the HX4. Multiple package names are separated by“,”. The default value is L, D, G L: Line Package D: DTMF Package G: Generic Media Package
Persistent line event	List the event types that the gateway can report, with multiple types separated by “,”. When gateways process the events listed here, they will report to the call agent. Note: This parameter must be set since there is no default value. The factory setting is L/HD, L/HU: L/HD: Offhook L/HU: Onhook
FXO event package	Handset Package or Line Package

Name	Description
Wildcard	<p>Select whether a wildcard with prefix is allowed when a gateway registers to the proxy server. The default value is “Not allowed”.</p> <p>Partially allowed: gateways will use a wildcard with fixed prefix (e.g. aaln / *) when registering. For example, when configuring telephone numbers, if line 1 is set to aaln/1, line 2 is set to aaln/2 and line 3 is set to aaln/3, the gateways will register to the call agent in aaln/* without the need of registering the lines individually.</p> <p>Allowed: the gateways will use a wildcard in registering without prefix.</p>
CR for End-of-Line	<p>Select whether CR is used as the end of line in the MGCP messages. Default not selected.</p>
Quarantine default to loop	<p>Select the Quarantine handle of gateways making a request to the outside. Default not selected.</p> <p>Selected: quarantine using loop mode, the gateways will continually notify all events as requested after receiving a request.</p>
Enable first digit timer	<p>Select the processing mode when there is no timeout parameter in the outside request received by the gateways. Default not selected.</p> <p>Selected: the gateways will report timeout in terms of its own timeout setting (the time interval set in non-dial timeout of configuration system parameters) when subscribers has not dialed up in time after offhook.</p>
Using configured digit map	<p>Select whether to activate the digit map configured by local gateway. Default not selected.</p>
Using notify instead of 401/402	<p>Set whether the gateways report “offhook events” to replace 401 messages in NTFY or report “on-hook events” to replace 402 messages in NTFY when responding to messages sent by the proxy server. Default not selected.</p> <p>Selected: the gateways will use NTFY messages to replace 401 and 402 messages.</p>
No name in default package	<p>Select if a package name is included when the gateways reply to the default package. Default not selected.</p>
Keep connection when on-hook	<p>Select if the gateways actively cancel connection disconnect when subscribers hook on. Default not selected.</p>

2.3.8 FoIP

After login, click **Basic** > **FoIP** to open this interface.

Figure 2-27 Fax Configuration Interface

Basic	Line	Trunk	Routing	Advanced	Call Status	Logs	Tools
Status	Network	VLAN	System	SIP	MGCP	FoIP	

Initial offer

Codec	G.729A/20,G.711U/20,G.711A/20	Modify
RTP port min.	10010	Modify
RTP port max.	10030	Modify

Fax configuration

Transport mode	<input checked="" type="radio"/> T.38 <input type="radio"/> G.711 pass-through
Maximum fax rate	<input checked="" type="radio"/> 14400bps <input type="radio"/> 33600bps
Port for fax transmission	<input checked="" type="radio"/> Use original RTP port <input type="radio"/> Use a new port
ECM mode	<input type="checkbox"/>
Packet size	30 ms
Signaling redundancy level	4 frame
Image Data Redundancy level	1 frame

[Save](#)

Table 2-10 Fax Configuration Parameters

Name	Description
Initial offer	
Codec	Click Edit , go to Basic > System page to configure. For details, see 2.3.4 System.
RTP port Min.	Click Edit , go to Advanced > Media stream page to configure. For details, see 2.7.8 Media Stream.
RTP port Max.	Click Edit , go to Advanced > Media stream page to configure. For details, see 2.7.8 Media Stream.
Fax configuration	
Transport mode	The device supports two fax modes: T.38 and G.711 transparent transmission. When fax messages are received or sent through an analog trunk, the G.711 transparent transmission mode is required. When fax messages are received or sent through an IP trunk, a T.38 or a G.711 transparent transmission mode needs to be selected according to an actual requirement and the mode supported by the IP phone operation platform. If both T.38 and G.711 transparent transmission modes are supported, T.38 is recommended because it is more stable.
Allow opposite terminal to switch to T.38	When the device sends a fax message in G.711 transparent transmission mode, if the other party sends a T.38 negotiation request, the device will respond to the request and automatically switch to the T.38 mode.
Adjustable parameters when the T.38 is enabled (Default values are recommended.)	

Name	Description
Maximum fax rate	Select the maximum transmission rate of the fax service. 33600bps indicates the highest-rate fax mode.
Port for fax transmission	Set whether to use a new RTP port when the gateway switches to the T.38 mode. The default value is Use original RTP port . <ul style="list-style-type: none"> • Use a new port: Indicates that a new RTP port is used. • Use original RTP port: Indicates that the original RTP port established during the call is used.
ECM mode	The error correction mode (ECM) for the fax service. When the Maximum fax rate is 14400 , the ECM mode is not used by default. When the Maximum fax rate is 33600 , the ECM mode is used by default.
Packet size	Set a data frame packet interval for T.38. The options include 30 ms and 40 ms. The default value is 30 ms.
Signaling redundancy level	Set the number of redundant data frames in T.38 data packets. The value range is 0–6 frames, and the default value is 4 frames.
Image Data Redundancy level	Set the number of redundant images in T.38 data packets. The value range is 0–2, and the default value is 1.

2.4 Line

2.4.1 Phone Number

The content below is only applicable to gateways with FXS ports.

After login, click **Line > Phone number** to open the configuration interface.

Figure 2-28 Configuration Interface for Phone Number

Basic	Line	Trunk	Routing	Advanced	Call Status	Logs	Tools
<i>Phone number</i> Feature Batch Advanced							
	FXS 1st line No.						Batch
	ID1				8000		
	ID2				8001		
	ID5				8004		
	ID6				8005		
							Save

Table 2-11 Configuration Parameters of Phone Number

Name	Description
FXS 1st line No.	This number is used for the batch setup of subscriber line. Click Batch after filling in initial number, the number of Line 1 adopts initial number; that of Line 2 increases 1 progressively based on that of Line 1, and so on.
ID n	Fill in the telephone number associated with the subscriber line n (FXS port). This should be manually performed if Batch mode is not used.

2.4.2 Subscriber Line Features

The content below is only applicable to gateways with FXS ports.

After login, click **Line > Feature** to open the configuration interface.

Figure 2-29 Subscriber Line Features Configuration Interface

Table 2-12 Subscriber Line Features Configuration Parameters

Name	Description
Phone ID	Fill in the port number associated with this port. "FXS-n" corresponds to the Line > Phone Number > ID n .
Phone number	Fill in the number associated with this port.
Display as	Fill in the display name which will be contained in the From field of SIP message. e.g. From: "Bob" <sip:8000@127.0.0.1>;tag=14340047091433920745-1, Bob is the display name.
Local SIP port	This parameter is displayed only when Multi port is selected in page Advanced > SIP . Set the port used for receiving and sending SIP messages associated with the line. If this parameter is not specified, the local port configured in Basic > SIP is used. Note: This parameter is displayed only when Multi port is checked on Advanced > SIP page.
Registration	Select if this line is required to register to a soft switch. This is selected by default.
User name	If Registration is selected, users must enter the user name for registering the line here. This is not mandatory. If this parameter remains blank, the phone number of the extension set is used.
Registrar password	If Registration is selected, users must enter the authentication password for registering of this line here.

Name	Description
Note: The following features are valid only in SIP protocol. When the gateways use MGCP protocol, features are controlled by the proxy server without the need to be set on the gateway.	
Hot line	Select if the gateway is required to automatically dial out the hotline number after offhook. By default, hot line is disabled. <ul style="list-style-type: none"> • Disable hot line: close this feature. • Hot line: automatically dial out the hotline number after offhook. • Delay mode: automatically dial out the hotline number when the offhook is timeout with a time delay of 5 second by default. You can change the delay time by setting the parameter hotline dialing delay on Line> advanced.
Color ringback tone	Select to activate CRBT (Color Ring Back Tone), then choose an audio file as ring back tone. There are two.dat files in the G.729 coding format (fring1.dat and fring2.dat) storage in MX for factory default. You can upload .wav files through the Web GUI, for details, see 2.7.12 Greeting .
Set up speed dial	Select if the Speed dials is activated on this line. By default, this is not selected.
Speed dial groups	Use "Abbreviated number-Phone number" (e.g. 20-13812345678). Use a forward slash "/" to separate each group of abbreviated numbers. The abbreviated numbers range from 20 to 49. A maximum of 399 bytes can be configured.
Call forwarding	Select if Call forwarding is activated on this line. By default, it is not selected.
Unconditional	All incoming calls are forwarded to the telephone number specified in this parameter.
No Answer	All incoming calls are forwarded to the telephone number specified in this parameter when they are not answered.
Busy	All incoming calls are forwarded to the telephone number specified in this parameter when the extension is busy.
Call Forking	Select to activate call forking. Forking allows the device to simultaneously dial the extension along with another telephone terminal (specified when function is activated). Either terminal may answer, when one side picks up, ringing on the other side will end.
Release control by caller	Select if the call release is controlled by the caller. By default, this is not selected. Selected: the gateway will immediately release the call when <i>caller</i> hangs up; the gateway will not release the call when <i>called party</i> hangs up as long as the caller is still off-hook until timeout (60 seconds by default); Unselected: the gateway will immediately release the call upon either party hanging up the call.
Loop open disconnect	Select only if the trunk of the PBX supports loop open signaling, in which the PBX takes the loop open as the indication of disconnection. Note: Loop open interval can be configured on the Advanced > Line page.
RFC6913	If this item is selected, the Fax over IP label carried in INVITE is supported.
Obtain caller ID info from	If a received INVITE message carries From and P-Asserted-Id header fields, the caller identification number will be selected according to this parameter. If the received INVITE message does not carry the P-Asserted-Id header field, caller identification numbers are obtained from the From header field. <ul style="list-style-type: none"> • P-Asserted-Id field preferentially: The caller identification information is preferentially obtained from the P-Asserted-Id field in the INVITE message. • From field only: The caller identification information is obtained from the From field in the INVITE message. From field only is selected by default.
Registration subscription	The device subscribes the registration status of the line. If the subscription is successful, the SIP server sends a NOTIFY message for notification of the registration status of the line. Note: This parameter is displayed only when IMS is selected and Registration subscription is checked on Advanced > SIP page.
Call waiting	Select if Call waiting is activated on this line. By default this is not selected.

Name	Description
Call hold	Select it to enable Call Hold on this line. By default this is not selected. Note: If this function is enabled, the gateways will automatically activate Call Transfer.
Call transfer by calling party	Select if Caller Transfer is activated on this line. By default, this is not selected. When A calls B, B picks up the call and A transfers the call to C. Note: The call hold must be activated before caller transfer.
Caller ID delivery	Set whether the calling number is sent to the called party. This feature requires the support of softswitch. By default this is selected.
Caller ID restriction	Set whether the number of this telephone is sent to the called party with support from platform. By default this is not selected
DND allowance	Select if Do Not Disturb is allowed to enable on this line. By default, this is not selected.
Outgoing call barring	Select if outgoing calls are barred on this line. By default, this is not selected.
Three-way calling	Select if 3-way service is activated, and by default this is not selected.
Polarity reversal signal sending	Select if reverse polarity signal sending is activated on this line. By default, this is not selected. Note: The gateways will provide reverse polarity signal when the phone is connected after this feature is activated.
Maintenance	Select if the line is set to maintenance status, in which the FXS port no longer supplies current to the phone. By default, this is not selected.
Subscribe MWI	Select if voice mail service is activated. This is not selected by default. (Also see MWI Re-subscription on page Advanced > SIP .)
DDI (Direct Dialing in)	Set whether DDI (Direct Dialing In) is activated, By default, this is not selected. Different from FXS, DDI is only used for incoming calls, and the gateways will not send dial tone after off-hook (calling in) on user side. Note: Reverse polarity signal must be activated on the gateways when DDI is used.
Recording	Select if recording service is activated, and by default this is not selected.

2.4.3 Subscriber Line Batch (Unavailable on the HX4E)

The content below is only applicable to gateways with FXS ports.

After login, click **Line > Batch** to open the configuration interface.

Step 1 Click , the following interface is shown. Choose batch configured features and click **OK**.

Step 2 Click  to activate this function to configure this parameter. For details of the parameter, see **Line > Feature**.

Figure 2-30 Feature Batch Configuration Interface

The screenshot shows a configuration interface with a top navigation bar containing tabs: Basic, Line, Trunk, Routing, Advanced, Call Status, Logs, and Tools. Below this is a sub-navigation bar with 'Phone number' and 'Feature' tabs, and a 'Batch' button. The main area is titled 'Advanced' and contains the following settings:

- Line: [Text input field]
- Registration:
- Hot line: [Dropdown menu: Disable]
- Color ringback tone: [Dropdown menu: --]
- Set up speed dial:
- Call forwarding:
- Call forking:
- Destination number: [Text input field]
- Release control by caller:
- Loop open disconnect:
- RFC6913:
- Obtain caller ID info from: *P-Asserted-Identity* header *FROM* header
- Registration subscription:

Additional features are listed in a grid below:

- Call waiting
- Call hold
- Call transfer by calling party
- Caller ID delivery party
- Caller ID restriction
- DND allowance
- Outgoing call barring
- Three-way calling
- Polarity reversal signal sending
- Maintenance
- Subscribe MWI
- DDI(Direct Dialing in)
- Recording

A 'Save' button is located at the bottom right of the configuration area.

2.4.4 Subscriber Line Characteristics

The content below is only applicable to gateways with FXS ports.

After login, click **Line** > **feature** to open the configuration interface.

Figure 2-31 Subscriber Line Characteristics Configuration Interface

Basic	Line	Trunk	Routing	Advanced	Call Status	Logs	Tools
Phone number Feature Batch <i>Advanced</i>							
Gain to IP		<input type="range" value="0"/>		0 dB			
Gain to terminal		<input type="range" value="-3.0"/>		-3.0 dB			
Impedance		<input checked="" type="radio"/> Complex <input type="radio"/> 600 Ω <input type="radio"/> 900 Ω					
Hook flash timer min		<input type="text" value="75"/>		ms (Range: 25 - 780 , Default: 75)			
Hook flash timer max		<input type="text" value="800"/>		ms (Range: 800 - 1400, Default: 800)			
Caller ID transmission mode		<input type="text" value="FSK"/> <input type="text" value="SDMF"/> <input type="text" value="After ringing"/> <input type="text" value="With parity"/>					
Hook debouncing		<input type="text" value="50"/>		ms (Range: 10 - 1000, Default: 50)			
Ring frequency		<input type="text" value="25"/>		Hz (Range: 15 - 50, Default: 25)			
Play busy tone for network fault		<input type="checkbox"/>					
Caller release		<input type="text" value="60"/>		s (Range: 15 - 180, Default: 60)			
Outpulsing delay		<input type="text" value="0"/>		ms (Range: 0 - 20000), 0: Outpulsing disable			
Loop open interval		<input type="text" value="1000"/>		ms (Range: 100 - 6000)			
Polarity reversal		<input checked="" type="radio"/> Outgoing <input type="radio"/> Bi-direction					
Polarity reversal delay		<input type="text" value="5"/>		s (Range: 0 - 30, Default: 5)			
Music on hold		<input type="checkbox"/>					
Call waiting with hunt group		<input type="checkbox"/>					
Message Waiting Indication		<input type="text" value="Disable"/>					
Hotline dialing delay		<input type="text" value="5"/>		s(Range: 2-20, Default: 5)			
<p>Distinctive Alert/Ringing</p> <p style="text-align: center;"><input type="button" value="Save"/></p>							

Table 2-13 Subscriber Line Characteristics Configuration Parameter

Name	Description
Gain to IP	Adjust the voice volume from the analog extension. The default is 0. Taking decibel as the unit, setting range is -3 ~ +3 decibels. -3 means declining of 3 decibels; +3 means the amplification of 3 decibels.
Gain to terminal	Adjust the voice volume to the analog extension. The default is -3. Taking decibel as the unit, setting range is -6 ~ +3 decibels. -3 means declining of 3 decibels; +3 denotes the amplification of 3 decibels.
Impedance	Select the parameter of FXS port line impedance. The optional values as below: <ul style="list-style-type: none"> • Complex (default value) • 600 (ohm) • 900 (ohm)
Hook flash time min	Used by the gateway to detect Hook Flash event, the default is 75 milliseconds. The gateway will ignore any flash that fall short of the shortest flash time. Generally, this value should not be less than 75 milliseconds.

Name	Description
Hook flash time max	Used by gateway to detect hook flash, the default is 800 milliseconds. The gateway will regard the flash duration between Hook flash time min and Hook flash time max as effective flash. Any flash lasting over the longest time will be considered by gateway as hang up. Generally, this value should not be less than 800 milliseconds.
Caller ID transmission mode	Select transmission mode of Caller ID signal from the FXS port to the phone. <ul style="list-style-type: none"> • FSK or DTMF • SDMF or MDMF • Sending Caller ID data before or after ringing • Sending Caller ID data with or without parity
Hook debouncing	Used by gateway to avoid phone status errors, with default of 50 milliseconds. When the duration from hang-up to off-hook falls short of this value, the gateway will ignore the status variation, and consider that the phone remains in hang-up status. In opposite case, the gateway will ignore the status variation, and consider the phone remains in off-hook status. Effective range of setting is 10~1000 milliseconds.
Ring frequency	Set the ringing frequency to be transmitted by gateway to the phone, ranging from 15 to 50 Hz, with default of 20 Hz.
Play busy tone for network fault	Play a busy tone upon off-hook when a network fault occurs.
Caller release	Set the delay release time of line as caller control method, with a default of 60 seconds. Effective range of setting is 15~180 seconds. This parameter is used in combination with the Release control by caller parameter in Line > Feature .
Outpulsing delay	Used when gateway's FXS port is connected with the trunk interface of PBXs. For calls from gateway to PBX, gateways will relay the extensions to PBX after the delay set here. Setting of 0 means no extension number relay. The default is 0 milliseconds.
Loop open interval	This parameter is used with the loop open disconnection request. The range is from 100 ms to 6000 ms.
Polarity reversal	Set the trigger for polarity reversal, the default is Outgoing . <ul style="list-style-type: none"> • Outgoing: transmit reverse polarity signal only when the outbound is connected; • Bi-direction: transmit reverse polarity signal for the connection of both inbound and out bound calls.
Polarity reversal delay	The delay time from a call being answered to the transmission of reverse polarity signal. The default value is 3 in seconds. Effective range of setting is 0 - 30 seconds.
Music on hold	Choose whether to play the background music while call waiting. This is not selected by default.
Call waiting with hunt group	Choose whether to activate hunt group feature for call waiting. Default not selected.
Message waiting indication (MWI)	Select the lighting method of message waiting indicator of voice mail here: None, Polarity reversed, FSK, high voltage lighting. Message waiting indicator refers to the special LED on a phone that lights up upon receiving a voice message. It is essential to understand whether the phone supports the indicator and lighting method when selecting the lighting method.
Hotline dialing relay	This parameter specifies the delay time before the preset hotline number is automatically dialed after hook-off. The default value is 5 seconds, and the value range is 2 to 20 seconds. This parameter works only if the delay mode is set for hotline function on Line > Feature page. See Table 2-12.
Distinctive Alert/Ringing	Set the parameter Alert-Info n according to the "Alert-Info" value provided on the SIP server. When the "Alert-info" value of received INVITE message matches with the Alert-Info n , ring cadence <i>n</i> is activated.
Alert-Info 1	Match with ring cadence 1.

Name	Description
Configure ring patterns for ring cadence 1	Configure ring patterns for ring cadence 1. e.g. 1: if the ring patterns are set to 2, 500, 500, 1000, 3000 , the ringing cadence is 0.5s on, 0.5s off; 1s on, 3s off. e.g. 2: if the ring patterns are set to 2000, 4000 , the ringing cadence will be 2s on, 4s off.
Alert-Info 2	Match with ring cadence 2.
Configure ring patterns for ring cadence 2.	Configure ring patterns for ring cadence 2. It is used with Alert-Info 2 .
Alert-Info 3	Match with ring cadence 3.
Configure ring patterns for ring cadence 3	Configure ring patterns for ring cadence 3
Alert-Info 4	Match with ring cadence 4.
Configure ring patterns for ring cadence 4	Configure ring patterns for ring cadence 4. It is used with Alert-Info 4 .

2.5 Trunk

2.5.1 Phone Number

Only a gateway with FXO ports can display this interface.

After login, click **Trunk > Phone number** to open the configuration interface.

Figure 2-32 Phone Number Configuration Interface

Table 2-14 Configuration Parameters of FXO Phone Number

Name	Description
FXO 1st line No.	This number is used for the batch setup of trunk line. Click Batch after filling in initial number, the number of Line 1 adopts initial number; that of Line 2 increases 1 progressively based on that of Line 1, and so on.
ID n	Fill in the telephone number associated with the trunk n (FXO port). This should be manually performed if Batch mode is not used.

2.5.2 Trunk Features

Only a gateway with FXO ports can display this interface.

After login, click **Trunk** > **Trunk** to open the configuration interface.

Figure 2-33 Trunk Line Features Configuration Interface

Table 2-15 Configuration Parameters of Trunk Features

Name	Description
Trunk ID	Select a trunk line required to configure. “FXO-n” corresponds to the Trunk > Phone number > ID n .
Phone number	Display phone number associated with the trunk set in Trunk > Phone number
Display as	Fill in the display name associated with this port.
Local SIP port	Set the port used for receiving and sending SIP messages on the line. If this parameter is not specified, the local port configured in Basic > SIP is used. This parameter is displayed only when multi port is selected in page Advanced > SIP . Note: This parameter is displayed only when Multi port is checked on Advanced > SIP page.
Registration	Select if this trunk registers with the SIP registration server. By default, this is not selected.
Password	If Registration is selected, the authentication password for registering this line must be entered here.

Name	Description
Note: The following features are valid only in SIP protocol. When the gateways use MGCP protocol, the control of all call services is provided by the proxy server without the need of these setting.	
Inbound handle	The gateways provide three scenarios for handling incoming calls on the FXO trunk: <ul style="list-style-type: none"> • Binding: when a telephone call reaches the FXO port, the gateways will route the call to a FXS port according to the DID number bound with the port. Note: Setting a number to be bound is required or this setting is invalid. • Second-stage dialing: when a telephone call reaches the trunk port, the gateways will provide the second dial tone and route the call according to the extension number entered. Dialing tone or voice prompt file can be changed by user. • Direct: the gateways will route the incoming call on FXO port n to the corresponding FXS port n. For example, a call made to the first FXO port is forwarded to the first FXS port. Note: Direct applies only to a device having both FXO and FXS ports.
Voice prompt	Play the second dial prompt uploaded on Advanced > Greeting file page
Dialing tone	Play the second dial tone configured on Advanced > Tones page.
RFC6913	If this item is selected, the Fax over IP label carried in INVITE is supported.
Registration subscription	Periodically send subscription messages to the SIP server. The period of sending the subscription messages is the same as the Registration expiration in Basic > SIP . Note: This parameter is displayed only when IMS is selected and Registration subscription is checked on Advanced > SIP page.
Polarity reversal signal detection	If a PSTN line supports reverse polarity, make the selection here. Or this setting is invalid. By default, this is not selected.
Caller ID detection	Select to enable the detection function of caller ID for this FXO port. By default, this is not selected.
Outgoing call barring	Select if this FXO port bars outgoing call service to the PSTN. By default, this is not selected.
Echo cancellation	Select if echo cancellation is enabled for this FXO (Line).By default, this is selected.
Connect signal delay	After making an outgoing call from a FXO port, the gateway will send a 200 OK message to the platform with a delay if this parameter is selected. If unselected, the system sends a 200 OK message to the platform after off hook on the FXO port. Also see Answer delay on page Trunk > Advanced .
Recording	Select if recording service is activated. This is not selected by default.

2.5.3 Trunk Batch (Unavailable on the HX4E)

Only a gateway with FXO ports can display this interface.

After login, click **Trunk > Batch** to open the configuration interface.

Step 1 Click , the following interface is shown. Choose batch configured trunks and click **OK**.

Step 2 Click  to activate this function to configure this parameter. For details of the parameter, see **Trunk > Feature**.

Figure 2-34 Trunk Batch Configuration Interface

The screenshot displays the 'Trunk Batch Configuration Interface' with the following elements:

- Navigation Tabs:** Basic, Line, **Trunk**, Routing, Advanced, Call Status, Logs, Tools.
- Sub-Tabs:** Phone number, Feature, **Batch**, Advanced.
- Configuration Fields:**
 - Trunk: Text input field with a copy icon.
 - Local SIP port: Text input field with a red 'X' icon.
 - Registration: Text input field with a red 'X' icon and a checkbox.
 - Inbound handle: Text input field with a red 'X' icon and a dropdown menu showing 'Binding'.
 - Binding number: Text input field with a red 'X' icon.
 - RFC6913: Text input field with a red 'X' icon and a checkbox.
 - Registration subscription: Text input field with a red 'X' icon and a checkbox.
- Advanced Features (Checkboxes):**
 - Polarity reversed signal detection
 - Echo cancellation
 - Caller ID detection
 - Connect signal delay
 - Outgoing call barring
 - Recording
- Action:** A blue 'Save' button at the bottom right.

2.5.4 Trunk Characteristics

Only a gateway with FXO ports can display this interface.

After login, click **Trunk** > **Advanced** to open the configuration interface.

Figure 2-35 Trunk Characteristics Configuration Interface

Basic	Line	Trunk	Routing	Advanced	Call Status	Logs	Tools
Phone number		Trunk	Batch	<i>Advanced</i>			
Gain to IP	<input type="range" value="0"/>		0 dB				
Gain to PSTN	<input type="range" value="-3.0"/>		-3.0 dB				
Impedance	<input checked="" type="radio"/> Complex <input type="radio"/> 600 Ω <input type="radio"/> 900 Ω						
Outpulsing delay	<input type="text" value="1000"/>		ms (Range: 100 - 3000)				
Caller ID detection	<input type="text" value="Before ringing"/>						
Ring relay	<input type="radio"/> FXS ring sync with FXO <input checked="" type="radio"/> FXS ring independently						
Busy line handle	<input type="radio"/> Voice prompt <input checked="" type="radio"/> Hand up						
PSTN failover	<input checked="" type="checkbox"/>						
Inbound first digit timeout	<input type="text" value="24"/>		s (Range: 10 - 60, Default: 24)				
Answer delay	<input type="text" value="12"/>		s (Range: 10 - 60, Default: 12)				
Off-hook for rejection	<input type="text" value="1000"/>		ms (Range: 500 - 5000, Default: 1000)				
On-hook protection time	<input type="text" value="400"/>		ms (Range: 100 - 5000, Default: 400)				
Polarity detection	<input checked="" type="checkbox"/>						
Caller number sending mode	<input type="radio"/> DISPLAY <input checked="" type="radio"/> FROM						
Busy detection							
Busy tone count	<input type="text" value="3"/>		Cycle (Range: 2 - 5)				
Tone-on duration	<input type="text" value="350"/>		ms (Range: 30 - 1000)				
Tone-off duration	<input type="text" value="350"/>		ms (Range: 30 - 2000)				
Detect dual-frequency busy tone	<input type="checkbox"/>						
<input type="button" value="Save"/>							

Table 2-16 Trunk Characteristics Configuration Parameter

Name	Description
Gain to IP	Adjust the volume of the voice sent from the PSTN to the device. Increase the value when the volume received by internal party is low. Range: -3.0 - +9.0 dB. It is set to 0 dB by default.
Gain to PSTN	Adjust the voice volume sent from the device to the PSTN. Increase the value when the volume received by external party is low. Range: -6.0 - +3.0 dB.
Impedance	Set the parameter of FXO impedance, with the default of 600 ohm. The optional settings are below: <ul style="list-style-type: none"> • Complex (default value) • 600 (ohm) • 900 (ohm)
Outpulsing delay	Set the time interval between the FXO going off-hook and the outpulsing of the first digit to the PSTN. The default is 600 in milliseconds. Note: This parameter is used to match the digit receiving response time of the PSTN PBX.
Caller ID detection	Before ringing; After ringing. The After ringing mode is generally used.

Name	Description
Ring relay	Select whether to relay the ring of inbound call to the FXS port when the Inbound handle mode for the FXO port is selected as Direct . The default is Phone ring independently .
Busy line handle	Either a voice prompt or hanging up can be applied to FXO port when an incoming call goes to the FXS port which is in busy. This only applicable when the Inbound handle mode for the FXO port is selected as Direct .
PSTN failover	Select to route a call to the PSTN through an FXO port when the IP network fails or if there is no response to the call request. Default selected.
Inbound first digit timeout	Set the timeout of calling DTMF on FXO port for inbound calls, ranging from 10-60 seconds, with default of 24 seconds.
Answer delay	Set the delay time for sending 200 OK, ranging from 10 to 60 seconds, with default of 12 seconds. This parameter is used in combination with the Connect signal delay in Trunk > Trunk page. See Table 2-15.
Off-hook for rejection	This parameter is used to specify how to reject an incoming call in the Direct mode (see Table 2-15) for the FXO port. For inbound calls to an FXO port, if the associated FXS port is busy, the gateway will hang up after off hook according to the time set by the parameter, so as to refuse the upcoming call. The duration of the off hook is 500~5000 milliseconds, with a default of 600 milliseconds
On-hook protection time	Protection period following hang up of FXO port. During this period, the gateway ignores any voltage variation of the line. Value range is 100~5000 milliseconds, the default is 400 in milliseconds.
Polarity detection.	Choose whether to activate the detection of reverse polarity signal of FXO port. Note the detection will work only when the trunk supports polarity reversal.
Caller number sending mode	<ul style="list-style-type: none"> • DISPLAY: include the incoming call number detected at the FXO port in the Display field and send it to the peer end. The From field carries the phone number associated with the FXO port. • FROM: include the incoming call number detected by FXO in the From field and send it to the peer end. No Display information is carried.
Busy detection	
Busy tone count	Set the number of consecutive times the gateway detects busy tone signals. Gateways will regard the busy tone signal with the repeat times specified here as a hang-up signal. Default is 2, effective range is 2 ~ 5(cycle).
Tone-on duration	Set duration of busy tone signal, the default is 350 in milliseconds.
Tone-off duration	Set the interval time of busy tone, the default is 350 in milliseconds.
Detect dual-frequency busy tones	To detect dual-frequency busy tones.
Busy tone frequency	If Detect dual-frequency busy tones is enabled, you need to specify the frequency to be detected. Unit: Hz.

2.6 Routing

2.6.1 Digit Map

After login, click **Routing > Digit Map** to open the dialing rules interface.

Figure 2-36 Configuration Interface for Digit Map

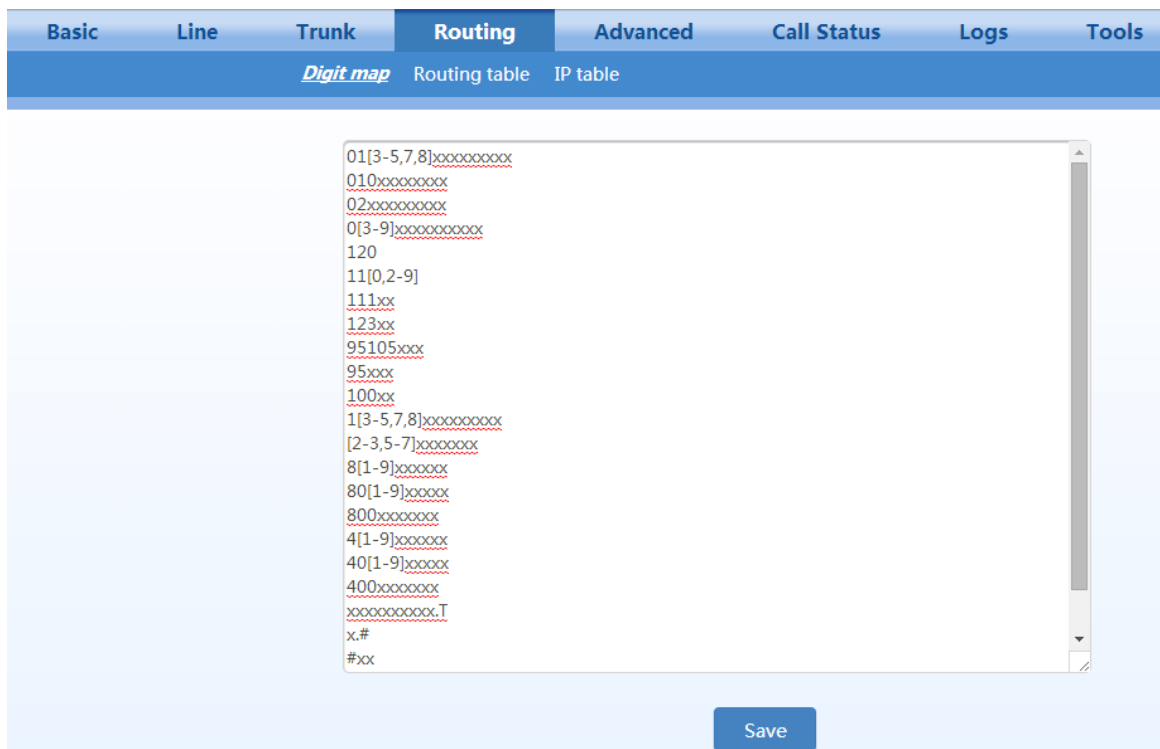

Dialing rules are used to effectively detect completed received number sequences that are ready to be sent in order to reduce connection time of telephone calls.

The maximum number of rules that can be stored in gateways is 250. Each rule can hold up to 32 numbers and 38 characters. The total size of the dialing rules table (all dialing rules) can be up to 2280 bytes.

The default digit map only contains system function rules. To customize the digit map, please choose the country in **Advanced > Tones** and input the rules you want in the text box. The following provides descriptions of typical rules:

Table 2-17 Description of Digit Map

Digit map	Description
x	Represents one digit between 0-9.
.	Represents more than one digit between 0-9.
##	After ## is detected, the gateway terminates the process of receiving digits. ## also functions as a special dial string for users to receive gateway IP address and version number of firmware by default.
xxxxxxxxxx.T	For a number with 10 digits, or less than 10 digits, the device terminates receiving digits and sends detected numbers if the duration of no dialing period exceeded the value of the Interdigit timer parameter. For a number with more than 10 digits, the device terminates receiving digits and sends detected numbers if the duration of no dialing period exceeded the value of the Complete entry timer parameter. Interdigit timer and Complete entry timer can be set on Basic > System page.
x.#	If subscribers press # key after dial-up, the gateways will immediately terminate the process of receiving digits and send all the numbers before # key.
*xx	Terminate after receiving * and any two-digit number. *xx is primarily used to activate function keys for supplementary services, such as CRBT, Call Transfer, Do not Disturb, etc.

Digit map	Description
#xx	Terminate after receiving # and any two-digit number. #xx is primarily used to stop function keys for supplementary services, such as CRBT, Call Transfer, Do not Disturb, etc.
[2-3,5-7]xxxxxxx	The gateway terminates receiving digits after receiving eight digits starting with any digits except 1, 4, or 9.
02xxxxxxxxx	The gateway terminates receiving digits after receiving 11 digits starting with 02.
013xxxxxxxxx	The gateway terminates receiving digits after receiving 12 digits starting with 013.
13xxxxxxxxx	The gateway terminates receiving digits after receiving 11 digits starting with 13.
11x	The gateway terminates receiving digits after receiving three digits starting with 11.
9xxxx	The gateway terminates receiving digits after receiving five digits starting with 9.
17911 (e.g.)	Send away when the set number, e.g. 17911, is received.

Dial rules by default are as follows:

01[3-5,7,8]xxxxxxxxx
010xxxxxxxxx
02xxxxxxxxx
0[3-9]xxxxxxxxx
120
11[0,2-9]
111xx
123xx
95105xxx
95xxx
100xx
1[3-5,7,8]xxxxxxxxx
[2-3,5-7]xxxxxxx
8[1-9]xxxxxx
80[1-9]xxxxx
800xxxxxxx
4[1-9]xxxxxx
40[1-9]xxxxx
400xxxxxxx
xxxxxxxxxx.T
x.#
#xx
*xx
##

2.6.2 Routing Table

After login, click **Routing** > **Routing Table** to open the configuration interface.

Figure 2-37 Routing Table Configuration Interface

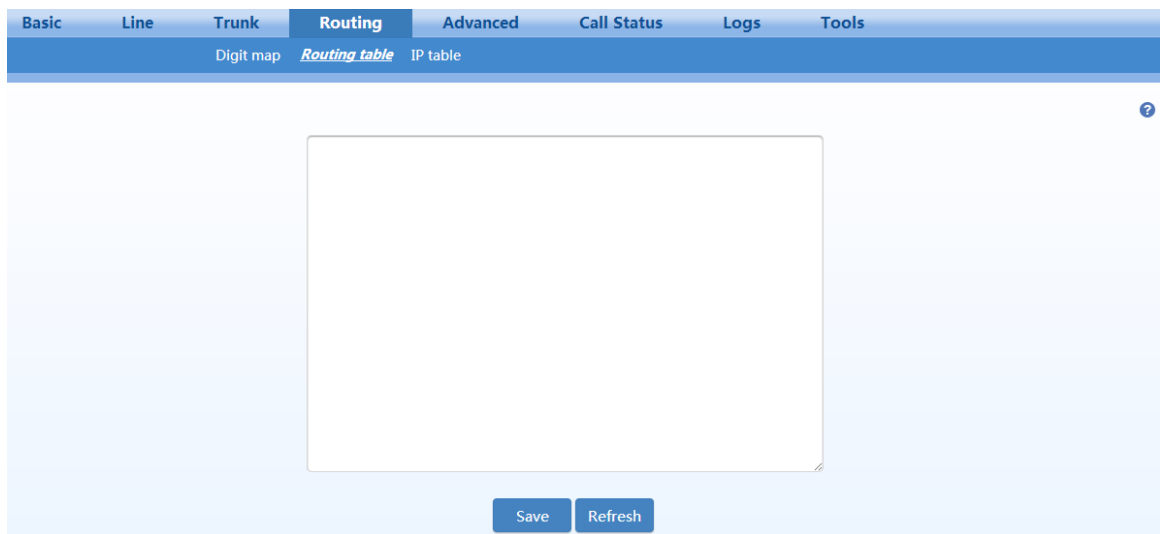

Click  to open the illustrative interface for routing configuration.

The routing table with a capacity of 500 rules provides two functions including number transformation and call routing assignment.

The device will match a rule from top to bottom.



Note

- Rules must be filled out without any blank at the beginning of each line; otherwise the data will not be validated even if the system prompts successful submittal.
- The routing table is empty by default. The gateways will direct a call to the SIP proxy server when there is no matched rule for the call.

The format of number transformation is

Source Number Transformation Method

Take **FXS 021 REMOVE 3** as an example. It indicates that, for a call from the FXS port (on a subscriber line), the first three digits area code 021 is removed from the called number. Where FXS is the source, 021 is the number, and REMOVE 3 indicates the method of number transformation.

The format of routing rules is

Source Number ROUTE Routing Destination

Take **IP 800[0-1] ROUTE FXO 1-2** as an example. It means that calls from IP with called number prefix 8000 or 8001 are routed to FXO port in a sequential order. Namely, FXO Port 2 is selected when FXO Port 1 is busy and so on.

Where IP is the source, 800[0-1] is the number, and FXO 1-2 is the routing destination.

For details of **Source** and **Number**, see Table 2-18.
 For details of **Number Transformation** and **Routing Destination**, see Table 2-19 and Table 2-20 respectively.

Table 2-18 Routing Table Format

Name	Description
Source	There are three types of source: IP, FXS (Phone/fax) and FXO (Line). The IP indicates any IP addresses. IP [xxx.xxx.xxx.xxx] indicates a specific address. IP [xxx.xxx.xxx.xxx:port] indicates an specific IP address and a specific port number. The FXS or FXO indicates any FXS or FXO port. FXS1, FXO2, FXS [1-2], or similar indicates a specific port.
Number	Specify a called party number. You can specify a calling party number in the form of CPN + number. The number may be denoted with digits 0-9, "*", ".", "#", "x", etc., and follows the format of the dialing rules. Here are a few ways you can format the number: Designate a specific number: eg. 114, or 61202700 Designate a number matching a prefix: such as 61xxxxxx. Specify a number scope. For example, 268[0-1, 3-9] specifies any 4-digit number starting with 268 and followed by a digit between 0-1or 3-9

Table 2-19 Number Transformations

Processing Mode	Description and Example
KEEP	Keep number. A positive digit following KEEP indicates the number of digits at the beginning of the sequence that is kept; a negative digit indicates numbers of digits at the end of the sequence that is kept. Example: FXS 02161202700 KEEP -8 Keep the last 8 digits of the called number 02161202700 for calls from FXS. The transformed called number is 61202700.
REMOVE	Remove number. A positive digit following REMOVE means to remove the number of digits at the beginning of the sequence; a negative number means to remove the number of digits at the end of the sequence. For example: FXS 021 REMOVE 3 Remove 021 of the called number beginning with 021 for calls from FXS.
ADD	Add prefix or suffix to number. If the number following ADD is positive, it is a prefix; if it is negative, it is a suffix. Example 1: FXS1 CPNX ADD 021 FXS2 CPNX ADD 010 Add 021 in front of calling numbers for calls from FXS port 1; add 010 in front of calling numbers for calls from FXS port 2. Example 2: FXS CPN6120 ADD -8888 Add 8888 at the end of the calling number starting with 6120 for calls from an FXS (Phone/fax) port.
REPLACE	Number replacement. The replacing number follows REPLACE. Example: FXS CPN88 REPLACE 2682000 Replace the calling number beginning with 88 for calls from FXS port with 2682000.

Processing Mode	Description and Example
REPLACE (continued)	<p>Another use of REPLACE is to replace the specific number based on another number associated with the call. For example, replacing the calling number according to the called number.</p> <p>Examples:</p> <pre>FXS 12345 REPLACE CPN-1/8621 FXS CPN13 REPLACE CDPN0/0</pre> <p>For calls from FXS ports with called party number of 12345, remove one digit at the end of the calling number and add 8621; for calls from FXS ports with calling party number starting with 13, add 0 at the beginning of the called number.</p>
END or ROUTE	<p>End-of-number transformation. From top to bottom, number transformation will be stopped when END or ROUTE is encountered; the gateways will route the call to the default routing upon detecting END, or route the call to the designed routing after detecting ROUTE.</p> <p>Example 1:</p> <pre>FXS 12345 ADD -8001 FXS 12345 REMOVE 4 FXS 12345 END</pre> <p>Add suffix 8001 to the called number starting with 12345 for calls from FXS ports, then remove four digits in front of the number to end number transformation yielding 58001.</p> <p>Example 2:</p> <pre>IP [222.34.55.1] CPNX. REPLACE 2680000 IP [222.34.55.1] CPNX. ROUTE FXS 2</pre> <p>For calls from IP address 222.34.55.1, calling party number is replaced by 2680000, and then the call is routed to FXS port 2 with the new calling party number.</p>
CODEC	<p>Designate the use of a codec, such as PCMU/20/16, where PCMU denotes G.711, /20 denotes RTP packet interval of 20 milliseconds, and /16 denotes echo cancellation with 16 milliseconds window. PCMU/20/0 should be used if echo cancellation is not required to activate.</p> <p>Example: IP 6120 CODEC PCMU/20/16</p> <p>PCMU/20/16 codec will be applied to calls from IP with called party number starting with 6120.</p>
RELAY	<p>Insert prefix of called party number when calling out. The inserted prefix number follows RELAY.</p> <p>Example:</p> <pre>IP 010 RELAY 17909</pre> <p>For calls from IP with called party numbers starting with 010, digit stream 17909 will be outpulsed before the original called party number is sent out.</p> <p>Example:</p> <pre>IP 010 RELAY 17909 ,,,</pre> <p>For a call from the IP end with the called number starting with 010, before the call is made, 17909 is automatically dialed first and three seconds later, the called number is dialed. One comma "," represents one second.</p>

Table 2-20 Routing Destination

Destination	Description and Example
ROUTE NONE	<p>Calling barring (also known as "blacklist").</p> <p>Example: IP CPN[1,3-5] ROUTE NONE</p> <p>Bar all calls from IP, of which the calling numbers start with 1, 3, 4, and 5.</p> <p>Block all calls from IP numbers starting with 1, 3, 4, 5</p>

Destination	Description and Example
ROUTE FXS	<p>Route a call to FXS port(s). Example 1: IP 800[0-3] ROUTE FXS 1-2 Select a port in sequential order.</p> <p>Example 2: IP 800[0-3] ROUTE FXS 1 Direct this call to FXS port 1.</p> <p>Example 3: IP 800[0-3] ROUTE FXS 1-2/R Select a port in round-robin order</p> <p>Example 4: IP 800[0-3] ROUTE FXS 1-2/G Select all idle ports and provide ringing.</p>
ROUTE FXO	<p>Route a call to FXO port(s). Example 1: IP x ROUTE FXO 1-2 Select a port in sequential order.</p> <p>Example 2: IP 800[0-1] ROUTE FXO 1-2/R Select a port in round-robin order.</p>
ROUTE IP	<p>Route a call to the SIP proxy server Example: FXS 021 ROUTE IP 228.167.22.34:5060 228.167.22.34:5060 is the IP address and port of the platform.</p>

2.6.3 Examples of Routing Rules

Examples of how routing table can be used to implement features:

- 1) Assigning One Phone with Dual Numbers
- 2) Hunt Group
- 3) Outbound Call Barring
- 4) Trunk Group for Outbound Calling

Assigning One Phone with Dual Numbers

For example, an analog extension of an FXS port, FXS1, of HX4E can be associated with two phone numbers: a PSTN number 61202701 and an extension number 1001. The PSTN number is used for direct inward dialing and the extension number is used for intercom. This feature can be supported by configuring the FXS1 number as 61202701 and adding the following routing rule to the routing table:

```
FXS 1001 ROUTE FXS 1
```

Hunt Group

A hunt group is a group of extensions, to which an inbound call is terminated following certain rules. Here is an example of terminating incoming calls from analog trunks to a hunt group consisting of ports FXS1 and FXS2 in round-robin fashion:

```
FXO x ROUTE FXS 1-2/R
```

Outbound Call Barring

Restrict users to make certain calls, such as an international call. Examples are as follows:

Routing Setting	Description
FXS[1] 0 ROUTE NONE	A calling starting with 0 is barred from dialing using the phone set at FXS1 port
FXS[1-2] 00 ROUTE NONE	A calling starting with 00 is barred from dialing using the phone set at FXS1 to FXS2 port. International call is not allowed.
FXS CPN2 ROUTE NONE	The telephone whose calling number starts with 2 at an FXS port is not allowed to make calls.

Trunk Group for Outbound Calls

An outbound trunk group consists of a set of trunks which are used for outbound calling following certain rules. Here is an example of routing all outbound calls from FXS port to the trunk group consisting of ports FXO1 to FXO4 in sequential fashion:

```
FXS x ROUTE FXO 1-4
```

Further, we set up the trunk group such that it is used only by calls to destinations with prefix 6120:

```
FXS 6120 ROUTE FXO 1-4
```

2.6.4 IP Table

The IP filtering function is used to ignore the VoIP messages from untrusted network.

After login, click **Routing > IP Table** to open the configuration interface.

Figure 2-38 IP Table Configuration Interface

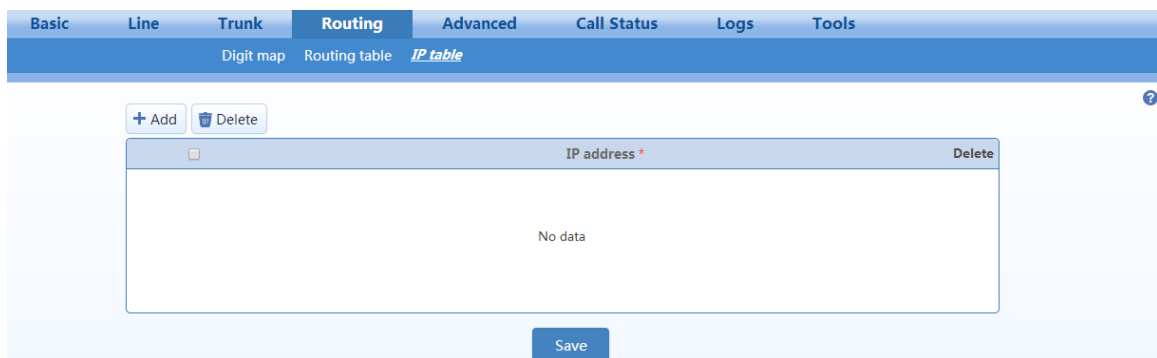

Add the authorized IP addresses to this table, the gateways will only process the VoIP signaling from authorized IP addresses. If the IP table is empty, the gateways will not perform IP address-based message filtering.



Note

If the gateway is deployed in a public network, you are advised to set IP filtering to prevent call theft.

2.7 Advanced Configuration

2.7.1 System

After login, click **Advanced > System** to open this interface.

Figure 2-39 Interface of system advanced configuration

The screenshot shows the 'Advanced' configuration page with the following sections:

- Recording:** Remote recording checkbox (unchecked).
- NAT:**
 - NAT traversal: Dynamic NAT (dropdown menu)
 - Refresh period: 15 s (more than 14, Default 15)
 - SDP address: Radio buttons for NAT IP address (unchecked) and Local IP address (checked).
- Auto provision:** Radio buttons for Enable (unchecked) and Disable (checked).
- Management system type:** Radio buttons for SNMP (unchecked) and TR069 (checked).
- Fields:** ACS-URL, Username, Password, Provisioning code, Model name, Periodic inform enable (radio buttons for On/Off, Off selected), Periodic inform interval (0 s, Range: 60 - 7200), Connection request URL.
- Buttons:** Save

Table 2-21 NAT Configuration Parameters

Name	Description
Remote recording	Call recordings are stored on an external Windows or Linux based recording server, on which the agent provided by New Rock collects and stores the call recording files. For more information, see the Recording Agent User Guide . Set this parameter to the IP address of the server. Note: The recording function needs to be enabled for the subscriber line.
NAT traversal	Gateways support several mechanisms for NAT traversal. Usually, static NAT is used when a fixed public IP address is available. It is necessary to perform port mapping or DMZ function on router when choosing dynamic or static NAT.
Refresh period	The refresh time must be filled in here when choosing dynamic NAT. Refresh time interval shall be determined by giving consideration to the NAT refresh time of the LAN router where the gateway is located. Gateway’s NAT holding function will carry out periodic operation according to this parameter. With seconds as its unit, default value of 60 seconds.
SDP Address	<ul style="list-style-type: none"> • NAT IP Address: Use NAT public address. • Local IP Address: Use the gateway’s IP address. Note: NAT IP Address is effective when the device successfully obtains NAT public address.

2.7.2 Auto Provisioning

After login, click **Advanced** > **System** to open this interface.

For specific configurations, see [Auto Provisioning Configuration Manual](#).

Figure 2-40 Interface of Auto Provisioning Configuration

Table 2-22 Auto Provisioning Configuration Parameters

Name	Description
Obtain ACS address via DHCP option 66	TFTP/HTTP/HTTPS ACS (Auto Provisioning Server) address is obtained by using option 66 of the DHCP.
ACS URL	Manually configure the address of ACS which could be a TFTP, FTP, or HTTP server. <ul style="list-style-type: none"> • tftp://ACS address • ftp:// ACS address • http://ACS address • https://ACS address
User name	Input a user name for accessing the ACS. Note: If the ACS is a TFTP server, the username and the password are not displayed.
Password	Input a password for accessing the ACS.
Firmware upgrade	Supports firmware download and update using ACS. Note: For the HX4E/MX8A, the firmware can be a tar.gz file or an img file. For the MX60/MX120/120G, the firmware is always a tar.gz file.
Update mode	The following modes are available. <ul style="list-style-type: none"> • Power on: the gateway detects whether there are configurations and firmware to be updated when the device is powered on. • Power on + Periodical: when the device is powered on, the gateway first checks whether there are configurations and firmware to be updated, and then periodically performs checking based on the set times.
Upgrade period	When Power on + Periodical is set, this parameter specifies the interval for periodic automatic upgrades. The default range is 3600 seconds. The value range is 5 to 84600 second.

2.7.3 Management System Type

After login, click **Advanced** > **System** to open this interface.

Figure 2-41 SNMP Configuration Interface

The screenshot shows the 'Management system type' configuration page. At the top, there are two radio buttons: 'SNMP' (which is selected) and 'TR069'. Below this, there are four input fields: 'Signaling port' with the value '2700', 'Server' (empty), 'Trap port' with the value '162', and 'Notification interval' with the value '900' followed by a small 's' for seconds. To the right of the 'Server' field, there is an example text 'e.g. 192.168.2.99'. At the bottom right, there is a blue 'Save' button.

Table 2-23 SNMP Configuration Parameters

Name	Description
Signaling port	Enter the SNMP local port. The default value is 2700. If SNMP is selected, the following three parameters need to be specified.
Server	Enter the address of the SNMP server.
Trap port	Enter the port number of the SNMP server. The default value is 162.
Notification interval	The default value is 900 seconds.

Figure 2-42 TR069 Configuration Interface

The screenshot shows the 'Management system type' configuration page with 'TR069' selected. At the top, there are two radio buttons: 'SNMP' and 'TR069' (which is selected). Below this, there are eight input fields: 'ACS-URL', 'Username', 'Password', 'Provisioning code', 'Model name', 'Periodic inform enable' (with radio buttons for 'On' and 'Off', where 'Off' is selected), 'Periodic inform interval' (with the value '0' and a note 's(Range: 60 - 7200)'), 'Connection request URL', 'Connection request username', and 'Connection request password'. At the bottom right, there is a blue 'Save' button.

Table 2-24 TR069 Configuration Parameters

Name	Description
ACS-URL	Specify the URL of the ACS.
User name	Set the user name used by the device to authenticate with the ACS.
Password	Set the password used by the device to authenticate with the file server
Provisioning code	Information of the device vendor, which may be used to indicate the primary service provider and other provisioning information to the ACS. It can be numbers or English letters.
Model name	A brief description of the interface type or name in the form of characters.
Periodic inform enable	A switch used to specify whether to periodically report to the ACS.
Periodic inform interval	The interval for reporting to the ACS.
Connection request URL	The address used for the ACS to connect back to the device.
Connection request username	The account used for the ACS to connect back to the device, for example, admin.
Connection request password	The password used for the network management server to connect back to the device.

2.7.4 Security Configuration

After login, click **Advanced** > **Security** to open the security configuration interface.

Figure 2-43 Security Configuration Interface

The screenshot displays the 'Advanced' configuration page for 'Security'. The navigation tabs include Basic, Line, Trunk, Routing, Advanced (selected), Call Status, Logs, and Tools. The sub-tabs under Security are System, Security (selected), Cert., White list, Media stream, SIP, RADIUS, Encryption, Greeting, Tones, Feature access codes, and System time.

The configuration is divided into four sections:

- Telnet/SSH:** Includes checkboxes for Telnet (checked) and SSH (unchecked). Fields for Password and Repeat password are present, along with a Save button.
- Ping:** Includes a radio button for Inbound Ping request, with 'Unblock' selected and 'Block' unselected. A Save button is located below.
- Web:** Includes input fields for HTTPS port (443) and HTTP port (80), both with a range of 1-9999. A Save button is located below.
- VPN:** Includes a radio button for Type, with 'Disable' selected and 'L2TP' and 'OpenVPN' unselected. A Save button is located below.

Table 2-25 Security Configuration Parameters

Name	Description
Telnet/SSH	
Telnet	If this parameter is selected, the Telnet service is enabled to allow a terminal to log in to the device through Telnet. It is disabled by default.
SSH	If this parameter is selected, the SSH service is enabled to allow a terminal to log in to the device through SSH. It is disabled by default.
Password	Specify the password for logging in to the device through Telnet or SSH. If both the Telnet and SSH services are enabled, the password will be shared. The password consists of 6 to 20 characters (letters, digits, or !@#%\$%^) and is case-sensitive.
Repeat password	Re-enter the specified password.
Ping	
	Block: The device is forbidden to respond to a Ping message. Unblock (default): The device is allowed to respond to a Ping message.
Web	
HTTPS port	Set the port for accessing the Web GUI of the device using HTTPS. The default value is 443 and the value range is 1 to 9999.
HTTP port	Set the port for accessing the Web GUI of the device using HTTP. The default value is 80 and the value range is 1 to 9999.



Note

If the gateway is placed in a public network environment, you should disable the Telnet function to prevent hacker attacks.

2.7.5 VPN (Available on the HX4E/MX8A)

A VPN is a virtual private network constructed on the public network. VPN technology is based on the idea of tunneling. It performs user authentication and data encryption to prevent data transferred over the public network from being invalidly browsed or changed. Because the VPN is a logical network constructed on the public network, it is unnecessary to deploy end-to-end physical links, only the VPN server and VPN client need to be deployed instead, which greatly reduces the network expense.

With a built-in VPN client, the HX4E/MX8A is ready to be directly connected to the VPN server to avoid the firewall issues and NAT issues.

When an untrusted network needs to be traversed between the HX4E/MX8A and the SIP server, you are recommended to construct a VPN network, and configure VPN client for HX4E/MX8A.

After login, click **Advanced > Security**, and then choose **L2TP** or **OpenVPN**.

Figure 2-44 VPN Configuration Interface

Table 2-26 VPN Configuration Parameters

Name	Description
VPN	Enable VPN client function.
Type	Disable VPN, or select L2TP or OpenVPN.
VPN server	Enter the IP address of the L2TP VPN server.
User name	Enter the user name provided by the L2TP VPN server.
Password	Enter the password provided by the L2TP VPN server.
OpenVPN client certificate	Note: Accurate device time is necessary for OpenVPN, please verify the device time on Advanced > System time page. To configure the OpenVPN, follow this procedure: 1. Select OpenVPN, and then click Save . 2. Click Upload to open the Advanced > Cert. page, and upload the OpenVPN client certificate. For details, see 2.7.6 Certificate. 3. After the certificate is uploaded, restart the device. 4. After the device is restarted, click Basic > Status to view the VPN connection status.

2.7.6 Certificate

After login, click **Advanced > Cert.** to open the interface.

Figure 2-45 Certificate Configuration Interface

Step 1 Prepare the OpenVPN certificate file “client.vpn” based on the information provided by the server. For details, see 4 Making an OpenVPN Client Certification.

Step 2 Click **Upload**.

Step 3 Select and upload the file client.ovpn.

Step 4 Reboot the device.

2.7.7 White list for Accessing Web and Telnet

The white list is used to specify the IP addresses from which accessing the device through Web or Telnet/SSH are allowed.

After login, click **Advanced** > **White list** to open the white list configuration interface.

Figure 2-46 White List Configuration Interface

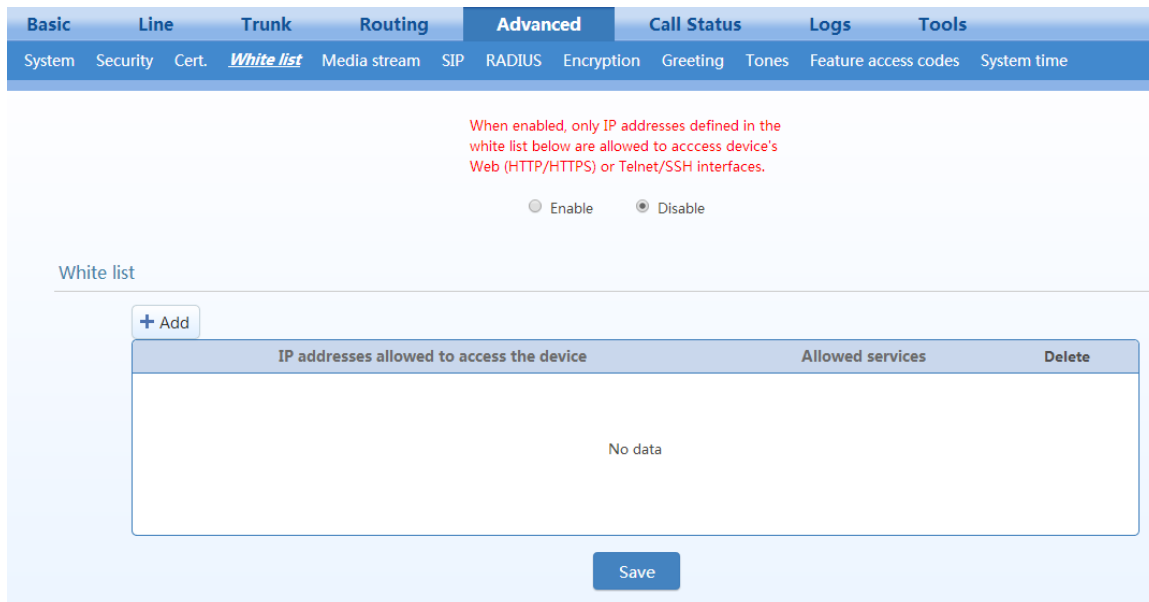

Step 5 Click **Add**.

Step 6 In the input box, enter IP addresses and types of services and click **Save**.

Step 7 Select **Enable**.



Note

- Being accessible by using Telnet/SSH requires to enable Telnet/SSH on **Advanced** > **Security** page.
- The device allows a white list of 20 entries.

2.7.8 Media Stream

After login, click **Advanced** > **Media Stream** to open this interface.

Figure 2-47 Media Stream Configuration Interface

Basic	Line	Trunk	Routing	Advanced	Call Status	Logs	Tools
System	Security	Cert.	White list	Media stream	SIP	RADIUS	Encryption
					Greeting	Tones	Feature access codes
							System time

RTP port min.	<input type="text" value="10010"/>	(Range: 3000 - 65535)
RTP port max.	<input type="text" value="10030"/>	(Range: 3020 - 65535)
SIP_TOS	<input type="text" value="0x00"/>	
RTP_TOS	<input type="text" value="0x0C"/>	Default 0x0C
Min. jitter buffer	<input type="text" value="2"/>	frame (Range: 0 - 30, Default: 3). Higher value results in long delay.
Max. jitter buffer	<input type="text" value="50"/>	frame (Range: 10 - 250, Default: 50)
RTP drop SID	<input type="checkbox"/>	
RTP obtaining	<input checked="" type="radio"/> From SDP global connection <input type="radio"/> From SDP media connection	

Table 2-27 Media Stream Configuration Parameter

Name	Description
RTP port Min.	The lowest port number of UDP ports for RTP transmission and receiving. The parameter must be greater than or equal to 3000. This is a required field. Note: each phone call will occupy RTP and RTCP ports. If the gateway is equipped with 4 subscriber lines (or trunk line), then at least 8 UDP ports are needed.
RTP port Max.	The highest port number of UDP ports for RTP's transmission and receiving. This is a required field. The value must be greater than or equal to "2 × number of lines + min. RPT port".
SIP_TOS	For SIP signaling, set the service quality for different priorities. The default value is 0x00.
RTP_TOS	For RTP voice streams, set the service quality for different priorities. The default value is 0x0c.
Min. jitter buffer	RTP Jitter Buffer is constructed to reduce the influence brought by network jitter. This parameter specifies the minimum number of RTP packets in the buffer. The default value is 2 frames. The value range is 0 to 30 frames.
Max. jitter buffer	RTP Jitter Buffer is constructed to reduce the influence brought by network jitter. This parameter specifies the maximum number of RTP packets allowed in the buffer. The default value is 50 frames. The value range is 10 to 250 frames.
RTP drop SID	Select to discard received RTP SID voice packets. By default, SID voice packets will not be dropped. Note: RTP SID packets should be dropped only when they are in nonconformity to the specifications. Nonstandard RTP SID data could generate noise for calls.
RTP obtaining	<ul style="list-style-type: none"> • From SDP global connection (default value): obtains the IP address from SDP global connection; • From SDP media connection: obtains the IP address from SDP Media Description.

2.7.9 SIP Configuration

SIP messages consist of request messages and response messages. Both include a SIP message-header field and SIP message-body field. The SIP message header mainly describes the message sender and receiver; SIP message body mainly describes the specific implementation method of the dialog.

Message of request: the SIP message sent by a client to the server, for the purpose of activating the given operation, including INVITE, ACK, BYE, CANCEL, OPTION and UPDATE etc.

Message of response: the SIP message sent by a server to the client as response to the request, including 1xx, 2xx, 3xx, 4xx, 5xx, and 6xx responses.

Message header: Call-ID.

Parameter line: Via, From, To, Contact, Csq, Content-length, Max-forward, Content-type, White Space, and SDP etc.

MX gateways provide flexibility in field setting in order to improve compatibility with the SIP register server.

After login, click **Advanced** > **SIP** to open this interface.

Figure 2-48 SIP Related Configuration Interface

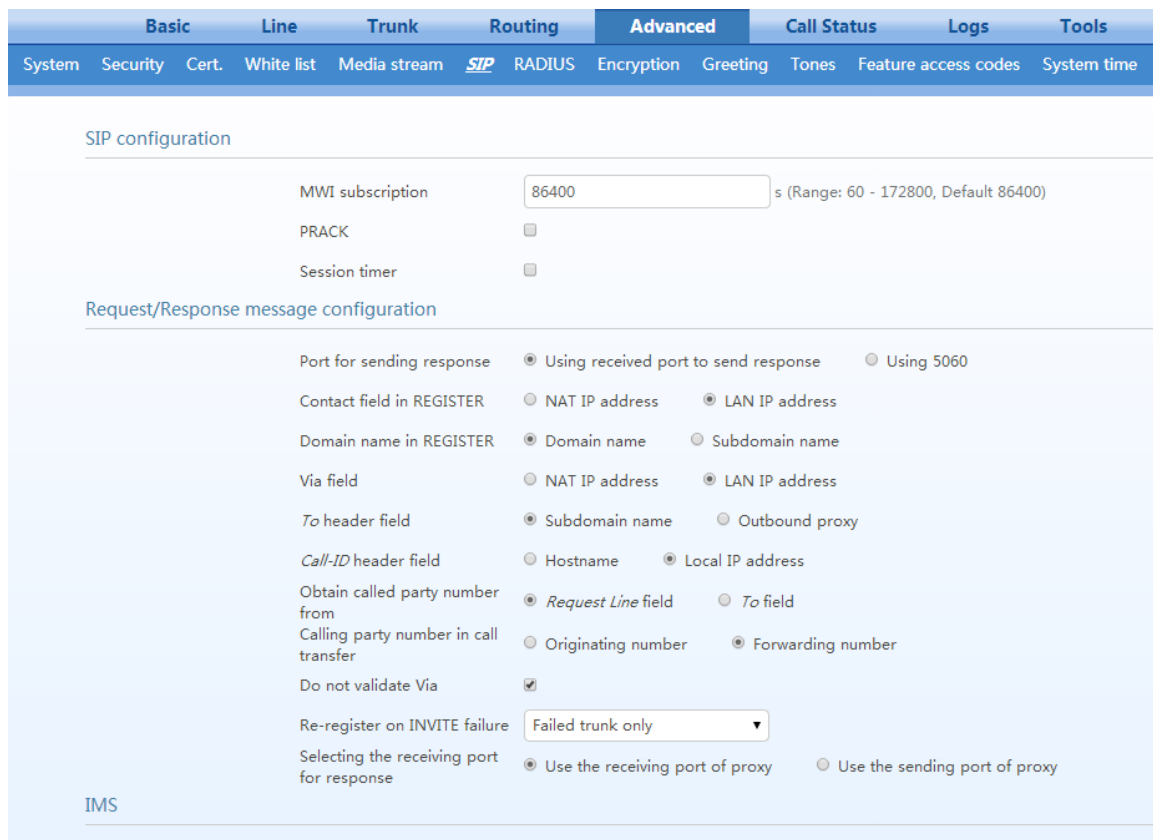

IMS IMS NGN

Early media RFC5009

Nextnonce Using <NextNonce> in 200 response Ignore <NextNonce>

Registration subscription

Multi port

SIP timer

Timer A	<input type="text" value="1000"/>	INVITE request retransmit interval, for UDP only
Timer B	<input type="text" value="16000"/>	INVITE transaction timeout timer
Timer D	<input type="text" value="16000"/>	Wait time for response retransmit
Timer E	<input type="text" value="500"/>	non-INVITE request retransmit interval, UDP only
Timer F	<input type="text" value="17000"/>	(Range: 2000 - 32000) non-INVITE transaction timeout timer
Timer G	<input type="text" value="2000"/>	INVITE response retransmit interval
Timer H	<input type="text" value="16000"/>	Wait time for ACK receipt
Timer I	<input type="text" value="5000"/>	Wait time for ACK retransmits
Timer J	<input type="text" value="16000"/>	Wait time for non-INVITE request retransmits
Timer K	<input type="text" value="5000"/>	Wait time for response retransmits

URI RFC 3966

Calling party number SIP TEL

Called party number SIP TEL

Parameter e.g. Request-Line: INVITE SIP:0351@xd.gt.com; user=phone SIP/2.0

Save

Table 2-28 SIP Related Configuration Parameter

Name	Description
SIP related configuration	
MWI subscription interval	The default is 86400 seconds. Set the time interval for which MWI service subscription request will be sent to the SIP server. This parameter should be used in conjunction with voice mail subscription on the page of the subject subscriber line.
PRACK	Determine whether to activate Reliable Provisional Responses. (RFC 3262)
Session timer	Choose to activate session refresh (RFC 4028). By default, session timer is not activated. By default, this is not selected.
Session interval	Set the session refresh interval that will be included in the Session-Expires field of INVITE or UPDATE messages. Default value is 1800 seconds.
Minimum timer	Set the minimum value of session refresh interval.
Request/Response message configuration	
Port for sending response	Select the port for sending SIP signaling responses: <ul style="list-style-type: none"> Using received port to send response Using 5060
Contact field in REGISTER	Select either the NAT IP address or the LAN IP address. <ul style="list-style-type: none"> NAT IP address: use the NAT information returned by registration server. LAN IP address: keep original content of Contact when register.

Name	Description
Domain name in REGISTER	The default is Domain name . Domain name : complete domain name used for registration (for example: 8801@registrar.newrock.com); Sub domain name : only use the common part of the name of domain (for example:
Via field	Choose to use NAT IP address or LAN IP address as the Via header field, the default is NAT IP address .
To header field	Choose whether to use Sub domain name or Outbound proxy as the To header field, the default is Sub domain name .
Call-ID header field	Choose whether to fill Call ID field with Host name or Local IP address, the default is Local IP address .
Obtain Called party number from	Choose whether the gateway acquires the called number from Request Line field or To field. The default is From Request line field .
Calling party number in call transfer	Under call forwarding, the calling party number sent can be chosen from the originating number or the forwarding number, the default is Forwarding number . For example: the subscriber line 2551111 on the gateway activates call forwarding feature and sets the destination to 3224422. When caller with 1305553333 calls 2551111, the call will be forwarded to 3224422: <ul style="list-style-type: none">• If Originating number is chosen, the number 1305553333 will be sent to 3224422 as calling party number;• If Forwarding number is chosen, the number 2551111 will be sent to 3224422 as calling party number.
Do not validate Via	Set to ignore Via field, By default, Via is ignored.
Re-register on INVITE failure	Set to activate registration of all trunks or only failed trunks upon timeout of INVITE message. By default, it is disabled.
Selecting the receiving port for response	Select either the receiving port of proxy or the sending port of proxy.
IMS	
IMS	Select either the IMS mode or the NGN mode.
Early media	Enable RFC5009. It is not enabled by default.
Media direction attribute	Set parameter values of the P-Early-Media header field: <ul style="list-style-type: none">• Supported• Sendrecv• Sendonly• Recvonly• Inactive The fields vary according to the type of SIP message. They should be set as required by the peer end. Note: This parameter can be configured after Early media is selected.
Nextnonce	Select to carry “nextnonce” in 200 OK message or ignore “nextnonce”.
Registration subscription	Select to subscribe registration status.
Multi port	A local SIP port can be assigned to each line.
SIP timer	
Timer A	INVITE request retransmit interval, for UDP only. It is 1000 ms by default.
Timer B	INVITE transaction timeout timer. It is 16000 ms by default.
Timer D	Wait time for response retransmits. It is 16000 ms by default.
Timer E	non-INVITE request retransmit interval, UDP only. It is 500 ms by default.

Name	Description
Timer F	non-INVITE transaction timeout timer. It is 17000 ms by default and ranges from 2000 to 32000 ms.
Timer G	INVITE response retransmit interval. It is 2000 ms by default.
Timer H	Wait time for ACK receipt. It is 16000 ms by default.
Timer I	Wait time for ACK retransmits. It is 5000 ms by default.
Timer J	Wait time for non-INVITE request retransmission. It is 16000 ms by default.
Timer K	Wait time for response retransmission. It is 5000 ms by default.
URI RFC 3966	
Calling party number	Select the address scheme for calling party: <ul style="list-style-type: none"> SIP: SIP URI is used, for example <sip:212@172.16.10.126>;tag=143349062153-1". "From: <tel:212>;tag=143349065857-1". TEL: tel URL is used, such as "From: <tel:212>;tag=143349065857-1".
Called party number	Select the address scheme for called party: <ul style="list-style-type: none"> SIP: SIP URI is used, for example "To: <sip:212@172.16.10.126>". TEL: tel URI is used, for example "To: <tel:212>".
user=phone Parameter	Places the user=phone field in front of the SIP version in the INVITE request. e.g. INVITE sip:212@172.16.10.126;user=phone SIP/2.0
TCP	This parameter is only available on the OCS gateway (for example, the MX8A-OCS).
Protocol type	Select SIP/TCP or SIP/UDP, and the default is UDP. Note: both peers must choose the same transmission type.
Local TCP port	Specify the local port used by SIP/TCP.

2.7.10 RADIUS (Unavailable on the HX4E)

After login, click **Advanced** > **RADIUS** to open this interface.

Figure 2-49 RADIUS Configuration Interface

The screenshot shows the RADIUS configuration interface with the following fields and options:

- Primary server:** Input field with example "e.g. 223.155.21.15:1813".
- Key:** Input field with note "It must be identical with what is configured on the server."
- Secondary server:** Input field with example "e.g. 223.055.21.16:1813".
- Key:** Input field with note "It must be identical with what is configured on the server."
- Retransmit time:** Input field with value "3" and note "s (Range: 1 - 10, Default: 3)".
- Retransmit times:** Dropdown menu with value "3".
- CDR type:** Checkboxes for Inbound, Outbound, Answered, and Unanswered.
- Save:** A blue button at the bottom right.

Table 2-29 RADIUS Configuration Parameter

Name	Description
Primary Server	Define IP address and port number of preferred Radius server. Note: if the port number is not yet configured, please use Radius default port number 1813.

Name	Description
Key	Set the share key to be used for encrypted communications between Radius client and server. Note: The share key should be configured the same for both client and server side.
Secondary Server	Set the IP address and port number of standby Radius server. When an error occurs in communications between gateway and preferred Radius server, the gateway will automatically activate standby Radius server. Note: In case of no configuration of port number, use default port number of 1813.
Key	The share key for communications between Radius client and standby Radius server. Note: The key should be configured the same for both client and server side
Retransmit timer	Set the overtime on response after transmission of Radius message, the default is 3 seconds. The retransmission will be performed If no response is given after the timeout.
Retransmit times	Set the times of retransmission of Radius message when no response is received. Default is 3 times.
CDR type	<ul style="list-style-type: none"> • Set whether to send RADIUS charge message for • Outbound calls • Inbound calls • When calls are connected • Unanswered calls

2.7.11 Encryption

After login, click **Advanced > Encryption** to open this interface.

Figure 2-50 Encryption Configuration Interface

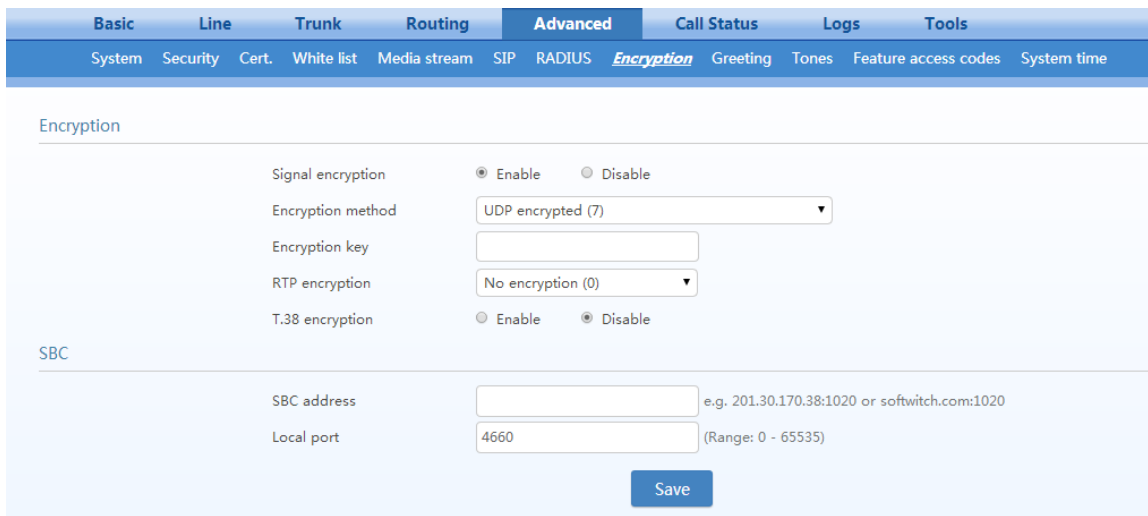

Table 2-30 Encryption Configuration Parameters

Name	Description
Signal encryption	Choose whether to encrypt signaling. By default, this is not selected.

Name	Description
Encryption method	Set the gateway encryption method, default is 7. The optional parameters as below: <ul style="list-style-type: none"> • 2:TCP not encrypted • 3: TCP encrypted • 6: UDP not encrypted • 7: UDP encrypted • 8: Using keyword • 10: RC4 • 13: Encrypt13 • 14: Encrypt14 • 16: Word reverse(263) • 17: Word exchange(263) • 18: Byte reverse(263) • 19: Byte exchange(263) • 20:VOS
Encryption key	You may obtain this from service provider
RTP encryption	Choose whether to encrypt RTP voice pack, the default is 0. <ul style="list-style-type: none"> • 0: no encryption • 1: entire message • 2: header only • 3: the data body only
T.38 encrypt	Select to encrypt T.38 fax media stream packets. By default, this is not selected.
Session Border Proxy	Encryption method numbered 2, 3, 6 and 7 are used only when the device is connected to a New Rock SBC.
SBC address	Set the IP address and port number of session border proxy server. The character “:” must be used between IP address and port number. Server address could be set into IP address or domain name. When a domain name is used, it is required to configure DNS server on the "Basic > Network" page. Example: 201.30.170.38:1020 or sbc.com:1020.
Local port	Signaling port assignment of the gateway, the default value is 4660. Signaling port number may be set at will, but cannot conflict with other ports of equipment.

2.7.12 Greeting

After login, click **Advanced > Greeting** to open the audio files interface.

Figure 2-51 Greeting Interface

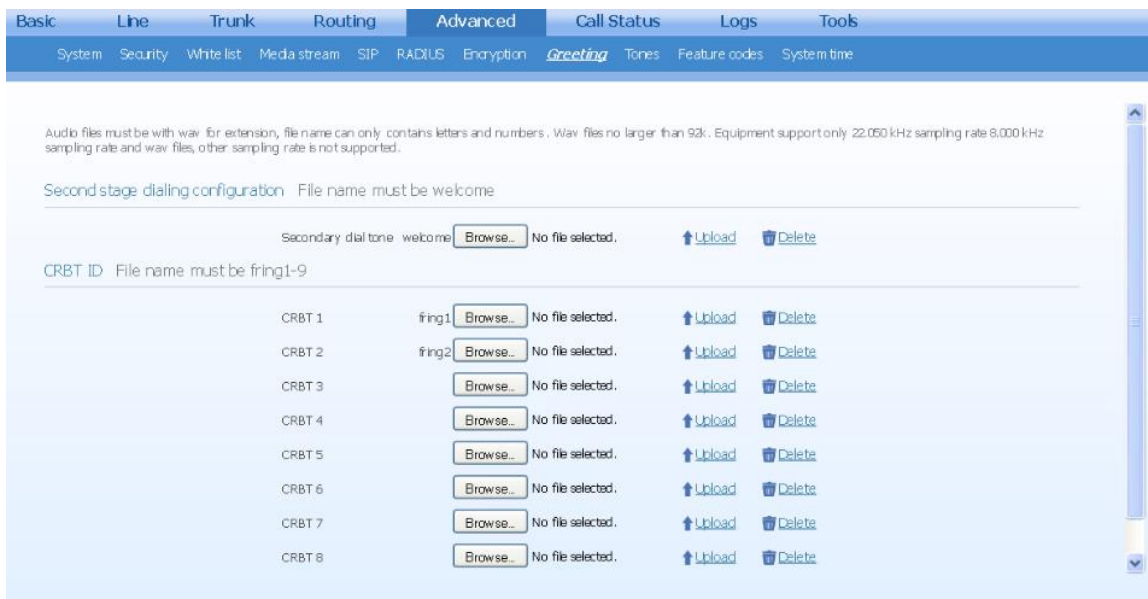

Table 2-31 Greeting Configuration Parameters

Name	Description
Second Stage Dialing Configuration	Click Browse , and then select the local audio file named welcome.wav . Click Upload . The uploaded audio file overwrites the original one. If you want to delete the current customized second stage dialing tone, click Delete . After the gateway restarts, the default second stage dialing tone will be used.
CRBT ID	Click Browse , and then select the local audio file named fring1/2/3/4/5/6/7/8/9.wav . Click Upload . The uploaded audio file overwrites the original one. If you want to delete the current color ringback tone, you can click Delete . After the gateway restarts, the default color ringback tone will be used.

2.7.13 Call Progress Tone Plan

After login, click **Advanced > Tones** to open this interface.

Figure 2-52 Call Progress Tone Configuration Interface

Parameter	Value
Country/Region	China
Dial tone	450/0
Second dial tone	400/0
Stutter dial tone	450/100,0/100,450/100,0/100,450
Busy tone	450/350,0/350
Congestion tone	450/700,0/700
Ring back tone	450/1000,0/4000
Off-hook warning tone	
Call waiting tone	450/400,0/4000
Confirm tone	450/100,0/100,450/100,0/100,450

Table 2-32 Call Progress Tone Configuration Parameters

Name	Description
Country/Region	There are progress tone plans for several countries and regions that are pre-programmed in gateways. Users may also specify the tone plan according to the national standard. Gateways provide tone plans for the following countries and regions: China, the United States, France, Italy, Germany, Mexico, Chile, Russia, Japan, South Korea, Hong Kong, Taiwan, India, Sudan, Iran, Algeria, Pakistan, Philippines, Kazakhstan, Singapore, Israel, Malaysia, Indonesia, United Arab Emirates, Zimbabwe, Australia. User-defined: define the call progress tones by yourself.
Dial tone	Prompt tone of off-hook dial tone.
Second dial tone	Second stage dial tone.
Stutter dial tone	Prompt of voice mail, or when the subscriber line is set with “Do not Disturb Service and Call Transfer”.
Busy tone	Busy line prompt.
Congestion tone	Notification of call set up failure due to resource limit.
Ring back tone	The tone sent to caller when ringing is on.
Off-hook warning tone	Reminds the subscriber when the phone is off-hook and no dialup has occurred.
Call waiting tone	Prompt the subscriber that another caller is attempting to call.
Confirm tone	Confirms function keys are being entered.

Here are examples that illustrate the various call-progress tones

- 350+440 (dial tone)
Indicates the dual–frequency tone consisting of 350 and 440 Hz
- 480+620/500,0/500 (busy)
Indicates the dual–frequency tone consisting of 480 and 620 Hz, repeated playing with 500 milliseconds on and 500 milliseconds off.
Note: 0/500 indicates 500 milliseconds mute.

- 440/300,0/10000,440/300,0/10000
Indicate a 440 Hz single frequency tone, repeated twice in the cadence of 300 milliseconds on and 10 seconds off.
- 950/333,1400/333,1800/333,0/1000
Indicate the repeated playing of 333 milliseconds of 950 Hz, 333 milliseconds of 1400 Hz, 333 milliseconds of 1800 Hz, and mute of 1 second.

2.7.14 Feature Codes

The feature codes consist of system feature codes and service feature codes. The system feature codes are used for acquiring gateway information, and the latter is used for users to activate and deactivate supplementary services.

After login, click **Advanced** > **Feature** to open this interface.

The following are the examples of the dialing rule for the feature codes:

Using *xx (dial * and 2 digits number) to activate a service

Using #xx (dial # and 2 digits number) to cancel a service.

This is illustrated with the following defaults for various parameters, which may be modified according to requirements.

It is highly recommended not to modify the default configuration in **System feature codes**.

Figure 2-53 Feature Codes Configuration Interface

The screenshot shows a web interface for configuring feature codes. At the top, there is a navigation bar with tabs: Basic, Line, Trunk, Routing, **Advanced**, Call Status, Logs, and Tools. Under the 'Advanced' tab, there are sub-tabs: System, Security, Cert., White list, Media stream, SIP, RADIUS, Encryption, Greeting, Tones, **Feature access codes**, and System time.

The main content area is titled 'System feature codes' and contains two input fields: 'Obtain IP address' with a default value of '##' and 'Query extension number' with a default value of '#00'.

Below this is a section for 'Service feature codes' with a collapse icon. It contains a table of configurations:

Activate CFU	*60	Deactivate CFU	#60
Activate CFB	*61	Deactivate CFB	#61
Activate CFNR	*62	Deactivate CFNR	#62
Activate CRBT	*80	Deactivate CRBT	#80
Call forking	*75	Deactivate forking	#75
Do not disturb	*72	Deactivate DND	#72
Speed dial	*74	Speed dial prefix	**
Suspend call waiting	*64	Blind transfer	*38
Audit CRBT	*88	Three-way calling	*79

A 'Save' button is located at the bottom right of the configuration area.

Table 2-33 Feature Codes Configuration Parameter

Name	Description
System feature codes	
Obtain IP address	The function key for obtaining the IP address of gateway, with a default of ##. When this function key is dialed, the phone will play the device IP address, the web port number for accessing the device, the IP address of the gateway, the subnet mask, and the system software version number. Note: If the device has only the FXO port, you can use Finder, a tool developed by New Rock, to obtain the IP address. If you want to have a copy of Finder, please send an email to gs@newrocktech.com.
Query extension number	The function key for obtaining the phone number of the subscriber line, with default of #00. By dialing this key, you will hear the phone number of the subscriber line voiced by the gateway.
Service feature codes	
	You can click <input checked="" type="checkbox"/> to allow the change of the service feature codes, or deselect the checkbox to not allow the change of the service feature code. By default, service feature codes are not allowed to change.
Activate CFU	The function key for activating unconditional call forwarding, with a default of *60. Dialing this key will activate unconditional call forward of the line and set the destination number for call forwarding. User operation: off hook → press *60 → enter the destination number. Users can determine the latest destination number set by dialing *60*. Note: It is required to enable call forwarding service before using this function (please see the instructions on the relevant configuration of subscriber line).
Deactivate CFU	The function key for deactivating unconditional call forwarding, with default of #60. User operation: off hook → press #60 → hang up.
Activate CFB	The function key for activating call forwarding when the line is busy, with default of *61. Dialing this key may activate CFB, and specify the destination number. It is required to enable call forwarding on busy service before using this function (See 2.4.2 Subscriber Line Features).
Deactivate CFB	The function key for deactivating call forwarding on busy, with default of #61. User operation: off hook → press #61 → hang up.
Activate CFNR	The function key for activating call forwarding on no answer, with default of *62. Dialing the function key should activate call forwarding on no answer and specify destination number. Note: It is required to enable call forwarding on no answer service before using this function (See 2.4.2 Subscriber Line Features).
Deactivate CFNR	The function key for deactivating call forwarding on no answer, with default of #62.
Activate CRBT	The function key for activating color ringback tone, with default of *80. Subscribers may select their favorite color RB tone by using this key. Note: It is required to start color ring service before using this function (See 2.4.2 Subscriber Line Features for how to assign the feature to the phone). User operation: upon off hook, the subscriber may press the function key (*80 by default), then input the two-digit index numbers of color ring. Dial *80* to listen to the color ring that has been previously set.
Deactivate CRBT	The function key for deactivating the color ring, with default of #80. The subscriber may use such key to recover the normal ring of phone. User operation: off hook → press #80 → hang up.
Call Forking	The function key for activating the double-ring/forking feature, with default of *75.
Deactivate forking	The function key for deactivating the feature, with default of #75.
Do not disturb	Activate do not disturb (DND), with default of *72. With DND selected, the gateway will reject all coming calls by sending busy tone to the callers. Note: It is required to start DND prior to using this function (See 2.4.2 Subscriber Line Features).
Deactivate DND	The function key to cancel DND, with default of #72. Dialing the function key may recover normal ringing upon the arrival of incoming calls.

Name	Description
Speed dial	Define the function key of dial, with default of *74. This key allows the user to build a table of 2-digits (20~49) speed-dial numbers. Note: It is necessary to get the dial-up service under way before applying this function (please see Phone for instructions on assigning the feature to the phone). User operation: upon dialing the function key (*74), dial the two-digit speed dial followed by the expanded number terminated with #.
Speed dial prefix	The prefix number for applying abbreviated dialing, with default of **. The prefix should be added in front of abbreviated dialing numbers when using abbreviated dialing. User operation: off hook → dial the prefix number of abbreviated dialing (**) and dial abbreviated dialing number (20).
Suspend call waiting	The function key for cancelling the call waiting feature for next call, with default of *64. Dialing this function key will temporarily disable the call waiting function for the next phone call. Note: The function key works only for single cancel, to cancel the call waiting complete, please refer to Table 2-12 about configuration of subscriber line .
Blind call transfer	The function key of blind call transfer, with default of *38. User operation: during the call, tap the phone hook switch or press R button → dial *38 → dial the called number and then hang up.
Audit CRBT	The function key for listening to the color ring, with default of *88. User operation: off hook → press *88 → input color ring number. While listening, you can press a two-digit CRBT index to change to another CRBT file.
Three-way calling	The default value is *79.

2.7.15 Clock Service

After login, click **Advanced** > **System time** to open this interface.

Figure 2-54 Clock Service Interface

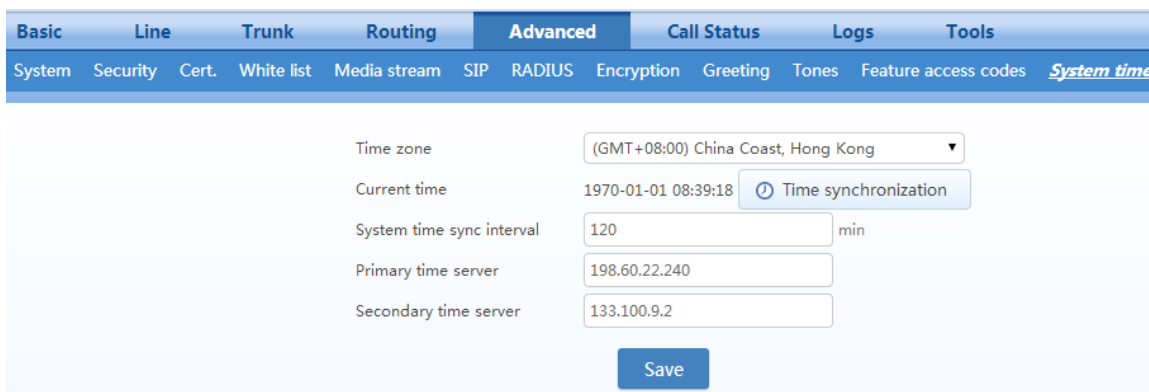

Table 2-34 Clock Service Parameters

Name	Description
Time Zone	Select a time zone, the parameter values include: <ul style="list-style-type: none"> • (GMT-11:00) Midway Island • (GMT-10:00) Honolulu, Hawaii • (GMT-09:00) Anchorage, Alaska • (GMT-08:00) Tijuana • (GMT-06:00) Denver • (GMT-06:00) Mexico City • (GMT-05:00) Indianapolis • (GMT-04:00) Glace_Bay • (GMT-04:00) South Georgia • (GMT-03:30) Newfoundland • (GMT-03:00) Buenos Aires • (GMT-02:00) Cape_Verde • (GMT) London • (GMT+01:00) Amsterdam • (GMT+02:00) Cairo • (GMT+02:00) Israel • (GMT+02:00) Zimbabwe • (GMT+03:00) Moscow • (GMT+03:30) Teheran • (GMT+04:00) Muscat • (GMT+04:00) United Arab Emirates • (GMT+04:30) Kabul • (GMT+05:30) Calcutta • (GMT+05:00) Karachi • (GMT+06:00) Almaty • (GMT+07:00) Bangkok • (GMT+07:00) Indonesia • (GMT+08:00) Beijing • (GMT+08:00) Taipei • (GMT+08:00) Singapore • (GMT+08:00) Malaysia • (GMT+09:00) Tokyo • (GMT+10:00) Canberra • (GMT+10:00) Adelaide • (GMT+11:00) Magadan • (GMT+12:00) Auckland
Current time	Display current time for the device. Click Clock calibration to calibrate the time.
System time sync interval	Set the synchronization period of the time. It is 120 minutes by default.
Primary time server	Enter the IP address of preferred time server here. It has no default value.

Name	Description
Secondary time server	Enter the IP address of Secondary time server here. It has no default value.

2.8 Status

2.8.1 Call Status

After login, click **Call Status** > **Call Status** to open this interface.

Figure 2-55 Call Status Interface

Connected: 0 Idle: 8 In-progress: 0 Other: 0 [Clear](#) [Refresh](#)

Line ID	Number	Register status	Line Status	Call Status	Phone No. (Other End)	Duration	In	Out	Answered	Operation
FXS-1	8000	Server not response	Idle	Idle			0	0		-
FXS-2	8001	Server not response	Idle	Idle			0	0		-
FXO-3	8002	Server not response	Disconnected	Idle			0	0		-
FXO-4	8003	Server not response	Disconnected	Idle			0	0		-
FXS-5	8004	Server not response	Idle	Idle			0	0		-
FXS-6	8005	Server not response	Idle	Idle			0	0		-
FXO-7	8006	Server not response	Disconnected	Idle			0	0		-
FXO-8	8007	Server not response	Disconnected	Idle			0	0		-

2.8.2 Call History on FXS

After login, click **Call Status** > **Call history on FXS** to open this interface.

Figure 2-56 Interface of Call History on FXS

Short call holding time (s) [Save](#) [Clear](#) [Refresh](#)

	Inbound calls from IP to FXS					Outbound calls from FXS to IP				
	Ring	Answered	Short call	Failure	Duration	Call attempt	Answered	Short call	Failure	Duration
Total	0	0	0	0	00:00:00	0	0	0	0	00:00:00
FXS-1	0	0	0	0	00:00:00	0	0	0	0	00:00:00
FXS-2	0	0	0	0	00:00:00	0	0	0	0	00:00:00
FXS-5	0	0	0	0	00:00:00	0	0	0	0	00:00:00
FXS-6	0	0	0	0	00:00:00	0	0	0	0	00:00:00

2.8.3 Call History on FXO

After login, click **Call Status** > **Call history on FXO** to open this interface.

Figure 2-57 Interface of Call on FXO

Basic	Line	Trunk	Routing	Advanced	Call Status	Logs	Tools			
Call status Call history on FXS Call history on FXO SIP message count										
Short call holding time <input type="text" value="0"/> (s) Save Clear Refresh										
Inbound calls from PSTN to FXO					Outbound calls from FXO to PSTN					
	Ring	Answered	Short call	Failure	Duration	Call attempt	Answered	Short call	Failure	Duration
Total	0	0	0	0	00:00:00	0	0	0	0	00:00:00
FXO-7	0	0	0	0	00:00:00	0	0	0	0	00:00:00
FXO-8	0	0	0	0	00:00:00	0	0	0	0	00:00:00

2.8.4 SIP Message Count

After login, click **Call Status** > **SIP message count** to open this interface.

Figure 2-58 SIP Message Count Interface

Basic	Line	Trunk	Routing	Advanced	Call Status	Logs	Tools
Call status Call history on FXS Call history on FXO SIP message count							
Clear Refresh							
Request							
	REGISTER	INVITE	ACK	BYE	CANCEL	INFO	Other
Send	0	0	0	0	0	0	0
Resend	0	0	0	0	0	0	0
Receive	0	0	0	0	0	0	0
Multiple receive	0	0	0	0	0	0	0
Response							
	200 OK	100 Trying	180 Ringing	183 Session progress	302 Moved temporarily	486 Busy here	487 Request terminated
Send	0	0	0	0	0	0	0
Receive	0	0	0	0	0	0	0
Other							
	1xx Provisional	2xx Success	3xx Redirection	4xx Client error	5xx Server error	6xx Global failure	
Send	0	0	0	0	0	0	-
Receive	0	0	0	0	0	0	-

2.9 Logs

2.9.1 System Status

Critical runtime information of gateways can be obtained in this interface, including:

- Information regarding login interface (including IP address and permissions of the user)
- SIP registration status
- Call-related signaling and media (RTP) information

After login, click **Logs** > **System Status** to open this interface.

Figure 2-59 System Status Interface

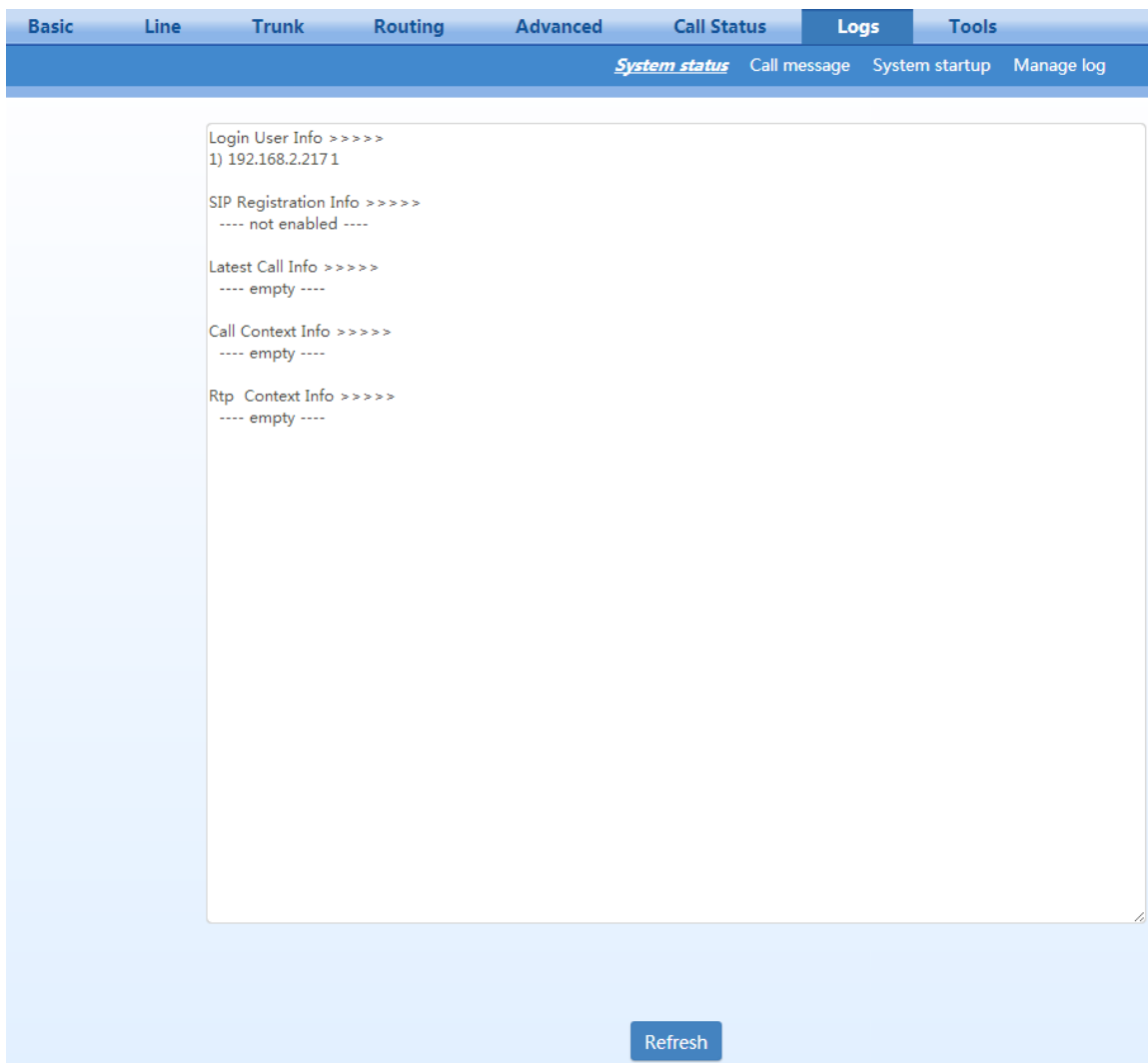

Table 2-35 System Status Parameters

Name	Description
Login User Info	<p>Show the IP address and permissions of the login user. The numbers following the IP address show the online permission level of the user: 1- administrator, 2 - operator, 3 – viewer. The viewer can only read the configuration.</p> <p>When more than one administrator log in at the same time, the first login’s permission level is 1, the other two users’ permission level is level 3; when more than one operator log in at the same time, the first user’s permission level is 2, the others are 3.</p>
SIP Registration Info	<p>Show registration status:</p> <p>Not enabled: the registration server’s address has not been entered;</p> <p>Latest response: the latest response message for the registration. 200 means the registration is successful;</p> <p>No response: no response from registration server. The cause may be contributed to 1) incorrect address for the registration server; 2) IP network failure; or, 3) the registration server is not reachable.</p>
Latest Call Info	Show the latest call.
Call Context Info (Call Context Info)	Show the call status.

Name	Description
Rtp Context Info	Show the voice channel related to the calls.

2.9.2 Call Message

After login, click **Logs > Call Message** to open this interface.

Figure 2-60 Call Message Interface

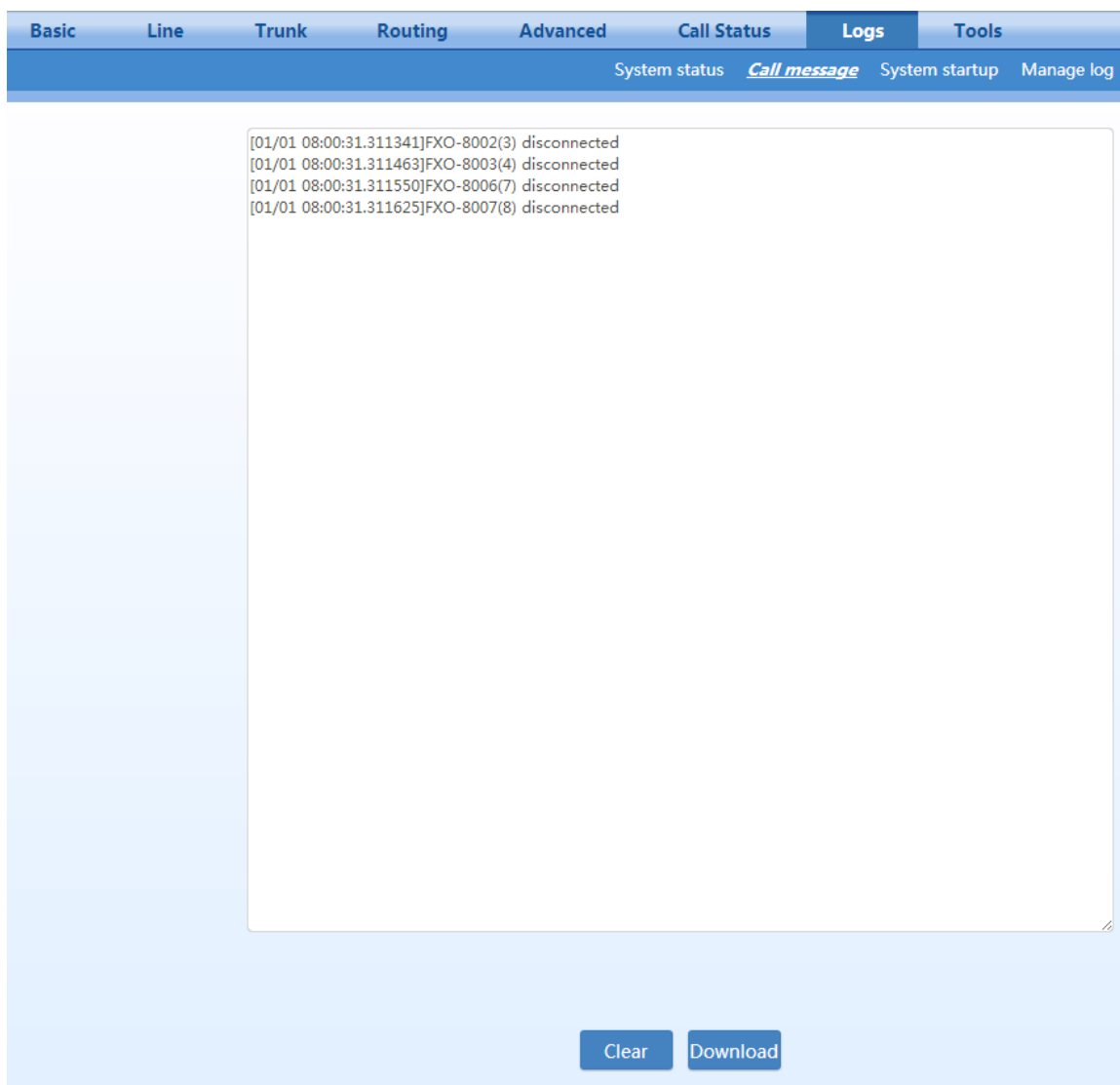

2.9.3 System Startup

After login, click **Logs > System Startup** to open this interface. Log files can be downloaded through this interface.

Figure 2-61 Interface of System Startup

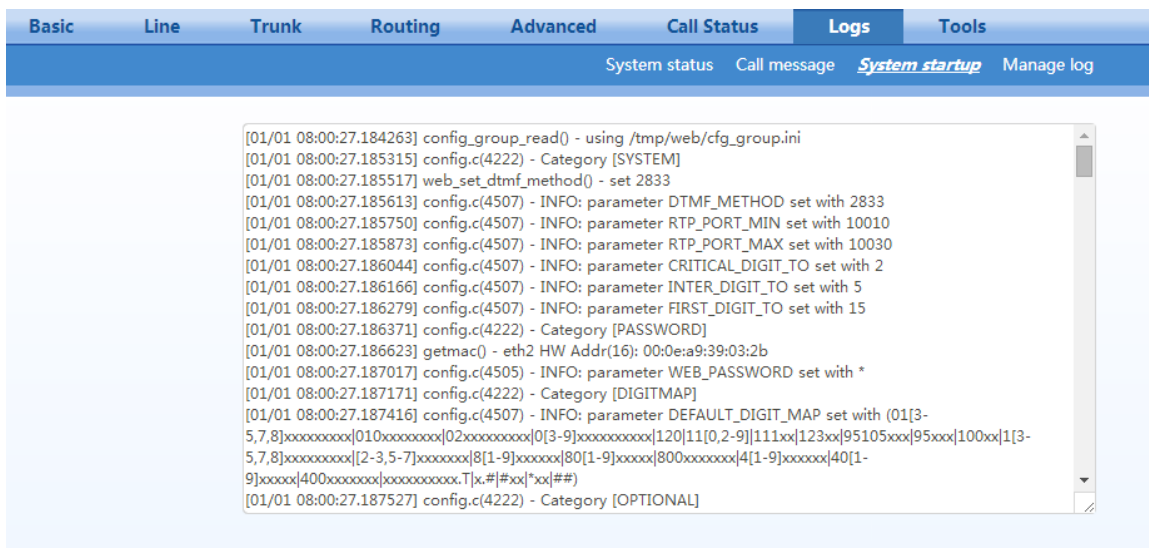

2.9.4 Manage Log

After login, click **Logs > Manage Log** to open this interface. Log files can be downloaded through this interface.

Figure 2-62 Manage Log Interface

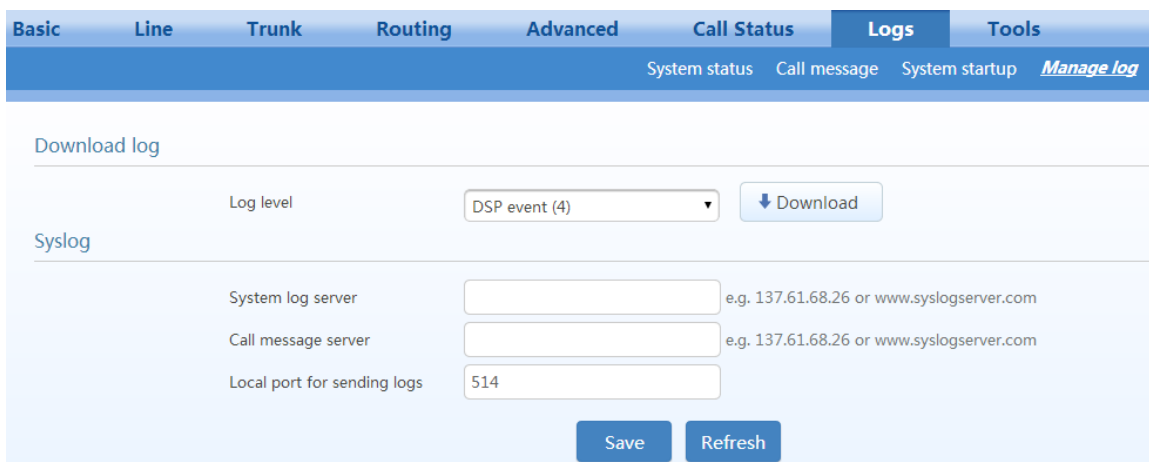

Table 2-36 Log Management Configuration Parameters

Name	Description
Download log	
Log level	Select the log file level of gateway, the default is 4. The higher the level the more details the log file will be. Note: To avoid reducing the system performance, log level should be set to 4 or lower when gateway is used in normal operation.
Syslog	
System log server	The syslog server receives the logs that are otherwise recorded in debug.log, message.log and boot.log.
Call message server	The syslog server receives the logs that are otherwise recorded in message.log.

Name	Description
Local port for sending logs	The port used to send logs.

Procedure for downloading the log:

- Step 1** Click **Download**, the gateway begins to assemble the logs.
- Step 2** After a few seconds, the interface of log saving will appear.

Figure 2-63 Log Saving Interface

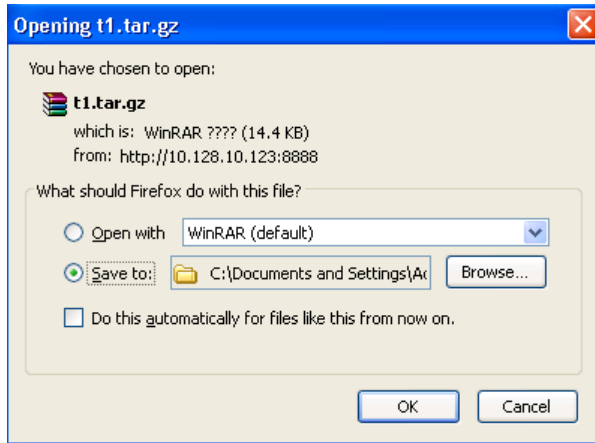

Step 3 Click **Save**, and select path to save.

Figure 2-64 Path Saving Interface

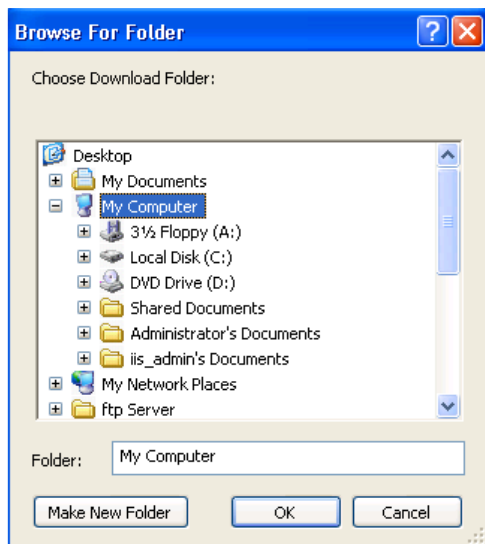

Step 4 The user may review the log file from the server.

2.10 Tools

2.10.1 Change Password

After login, click **Tools** to open this interface. Only the administrator is entitled to change the password of login.

To change the administrator password, enter old password in the **Old password field**, then enter new password in the **New password field** and the **Repeat new password field**, and then click **Save**.

The administrator can simply change the operator's password by entering the new password into **Operator password > New password**.

Figure 2-65 Password Change Interface

2.10.2 Configuration Management

After login, click **Tools>Import data** to open this interface.

The download procedure is similar to the download procedure of log files.

The steps for importing configuration files are the same as the Upgrade. The steps for exporting configuration files are the same as the steps for **Log Download**.

Figure 2-66 Configuration Management Interface

2.10.3 Upgrade

The software upgrade procedure is presented as below:

Step 1 Obtain the upgrade files (tar.gz file), and save the file onto a local computer.

Step 2 Click **Tools > Software upgrade** to access to the page of software upgrade.

Figure 2-67 Upgrade Interface

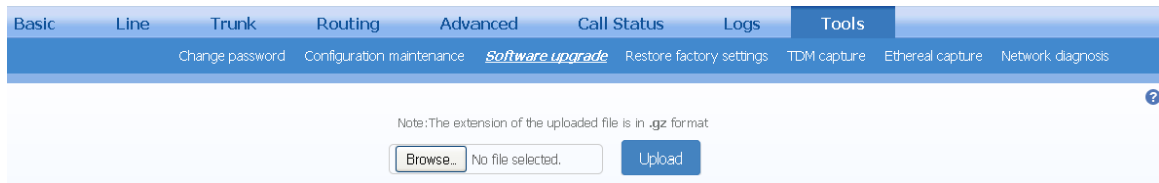

Step 3 Click **Browse** to select the upgrade files.

Figure 2-68 File Upload Interface

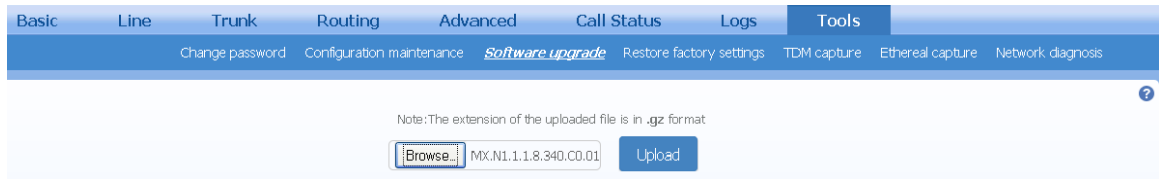

Step 4 Click **Upload**.

Step 5 Uploading will be completed in about 30 seconds, then click **Next**.

Figure 2-69 Upgrade Interface

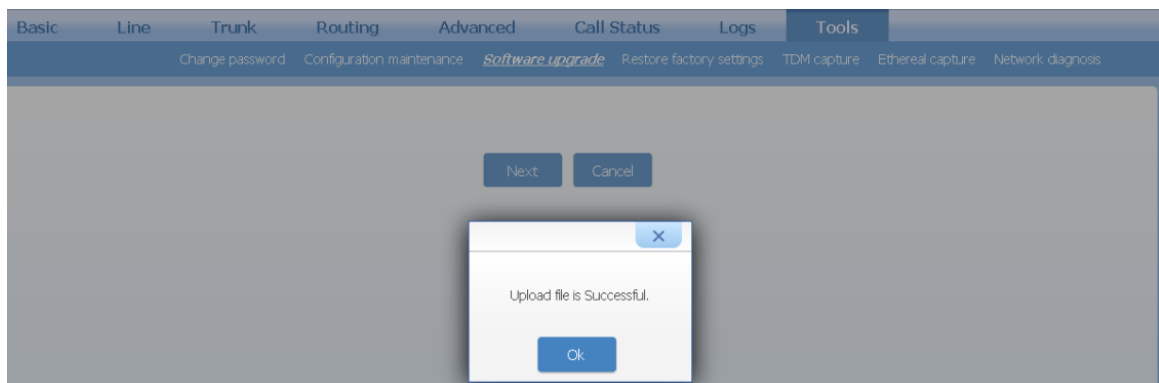

Step 6 The following prompt appears during the upgrade.

Figure 2-70 Upgrade Process Screen

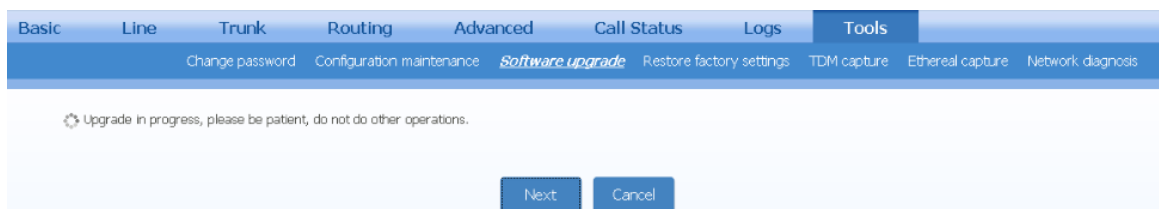

 **Note**

A few minutes are needed to upgrade the gateway. Do not operate the gateway during this period.

Step 7 The device automatically restarts after upgrade is successful.

Figure 2-71 Interface for Completing Device Restart after Upgrade

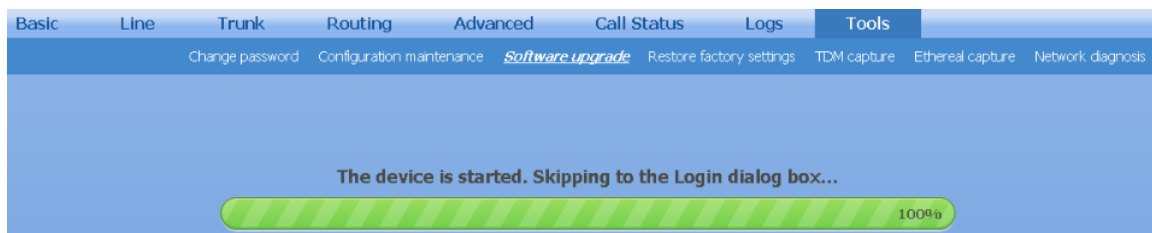

Wait for about two minutes, and access the interface of gateway management system, click **Info** and check the software version.

2.10.4 Restore Factory Settings

After login, click **Tools > Restore factory settings**.

The factory settings are designed based on common applications, and therefore, there is no need to modify them in many deployment situations.

You can choose to restore network or telephony related factory settings, or both.

Restoration takes effect after the system is restarted.

Figure 2-72 Restore Factory Settings Interface

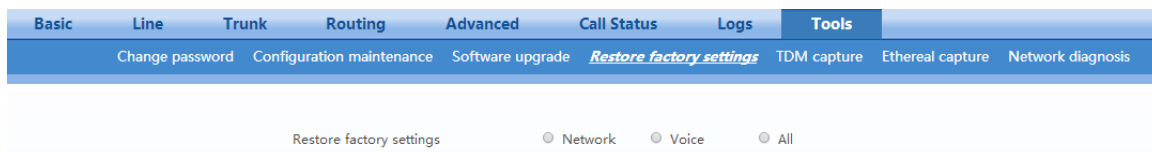

2.10.5 Capture Recordings on the Port

After login, click **Tools > TDM capture** to open this interface. This tool can be used to capture the voice stream from the Phone or Line interface. When the call lasts longer than 200 seconds, only the first 200 seconds of voice stream will be captured. The voice file is stored on the gateway in PCMU format.

Figure 2-73 Interface for Capturing Port Recordings

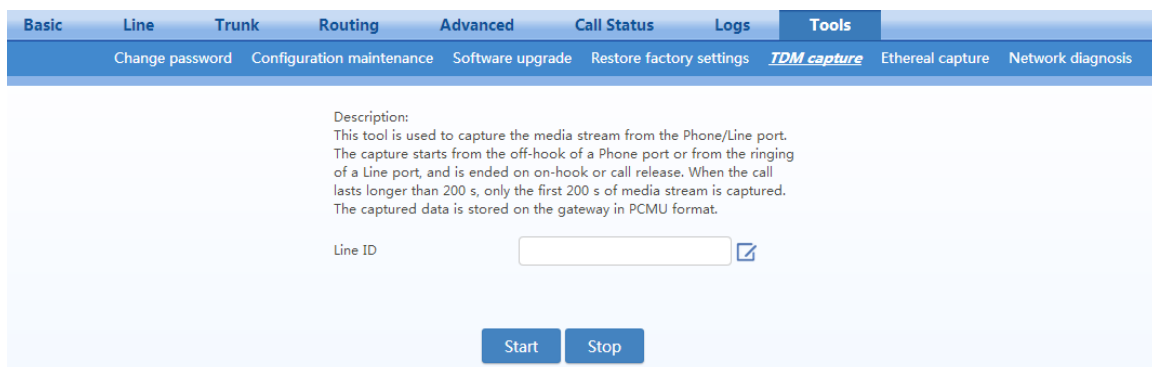

2.10.6 Ethereal Capture

After login, click **Tools > Ethereal capture** to open this interface. You are allowed to capture up to three IP voice data files, each with up to 2M bytes. The data files are stored on the gateway in dump.cap format under catalog /var/log.

Figure 2-74 Ethereal Capture Interface

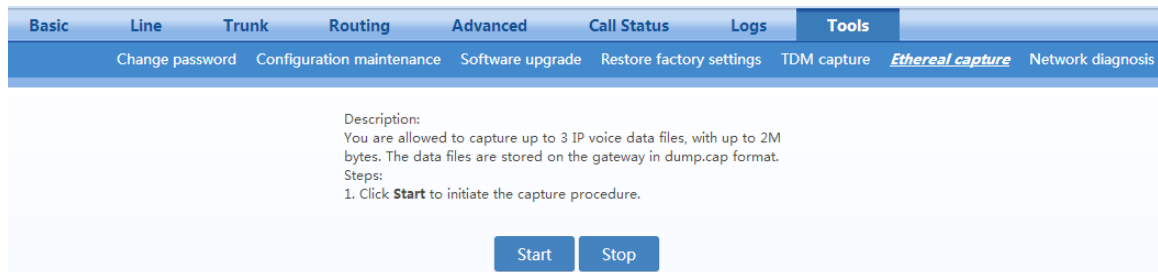

2.10.7 Network Diagnosis

After login, click **Tools > Network diagnosis** to open this interface.

If the Internet is unavailable, you can use this tool to diagnose whether the network is connected.

Figure 2-75 Automatic Diagnosis Interface

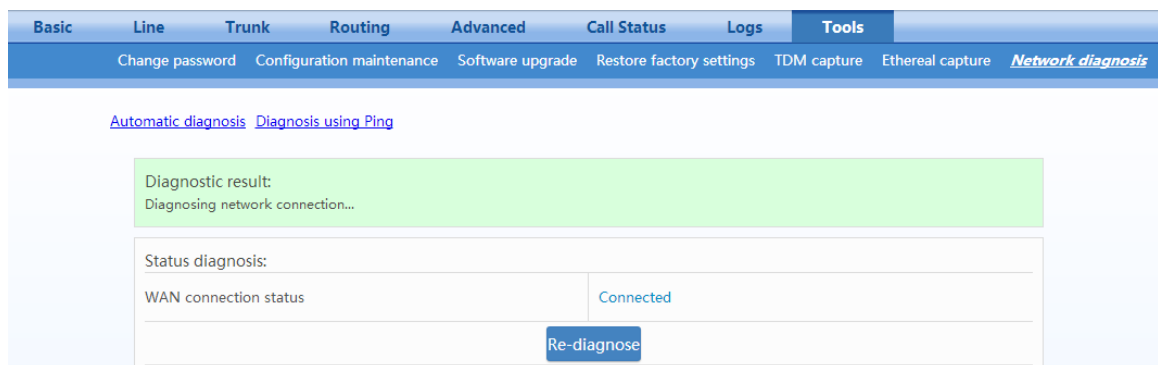
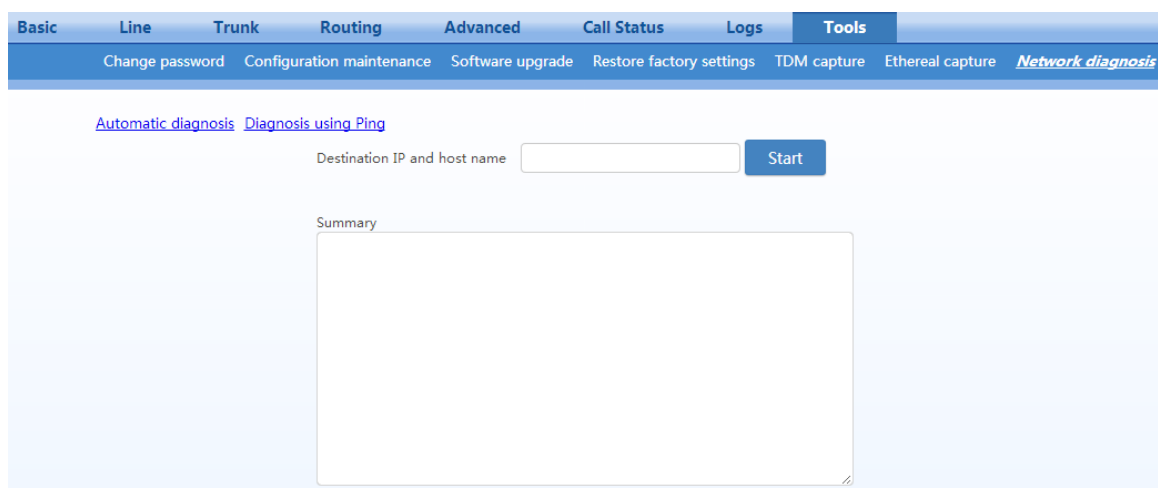

Figure 2-76 Ping Diagnosis Interface



2.11 Product Information

After login, click **Version info** to view the gateway hardware and software version information.

2.12 Reboot

To restart the gateway, click **Reboot** in the top right corner.

2.13 Logout

After login, click the **Logout** at top right to exit the gateway management system and return to the login interface.

3 Appendix: VLAN Configuration

Virtual Local Area Network (VLAN) virtually divides a physical LAN into multiple broadcast domains. Only hosts in the same VLAN can directly communicate without a router, so broadcast packets are restricted to the same VLAN, improving network security (e.g, a data-only VLAN or voice-only VLAN). VLAN technology identifies the VLAN information of a data packet by adding the VLAN tag field in the Ethernet frame header.

As voice traffic is delay and jitter sensitive, it requires higher priority over data traffic to reduce delay and packet loss during transmission. The switch connected with VoIP device can be configured to transmit the voice traffic in a dedicated VLAN, called voice VLAN.

When a gateway connect a switch provided VLAN, configurations such as VLAN tags and priorities are required for the gateway.

The following methods are used for configuring VLANs:

- Manual configuration: Via a web-based GUI, restart is required after the configuration.
- Automatic discovery (LLDP): With Link Layer Discovery Protocol (LLDP) enabled, during startup the device automatically obtains VLAN configuration information via an LLDP message, adds VLAN tag in packets it sends, and obtains network information such as IP address using the DHCP mode by default.
- Automatic discovery (DHCP): The device obtains the VLAN tag and QoS using DHCP option 132 and option 133.

New Rock gateways support two VLAN modes: single VLANs and multi-service VLANs (including voice and management VLANs). Manual mode is used to configure single and multi-service VLANs. Automatic discovery mode (by LLDP or DHCP) can configure only single VLANs.



Note

- A reboot is required to enable the VLAN configuration.
- After a VLAN is configured, only PCs in the same VLAN can access the device.
- The device address used to log in to the Web GUI can be obtained by connecting a phone to an FXS port of the device, and dialing ##. In the case of a single VLAN, the IP address of the single VLAN is voiced; in the case of a multi-service VLAN, the IP address of the management VLAN is voiced.

3.1 Automatic Discovery

All services of the device are on the same VLAN, and the device receives only data packets carrying the VLAN and includes the VLAN tag in all sent data packets. All device services belong to the same VLAN.

The device receives only data packets that carry the VLAN tag and includes the VLAN tag in all sent data packets. In this mode, the physical network port of the device has no separate address and shares the IP address of the VLAN interface.

3.1.1 LLDP

With Link Layer Discovery Protocol (LLDP) enabled, during startup the device automatically obtains VLAN configuration information via an LLDP message, adds VLAN tag in packets it sends, and obtains network information such as IP address using the DHCP mode by default.

Configuration

After login, click **Basic > VLAN**. Set **LLDP** to **on**, set **LLDP packet interval**, and then click **Save**.

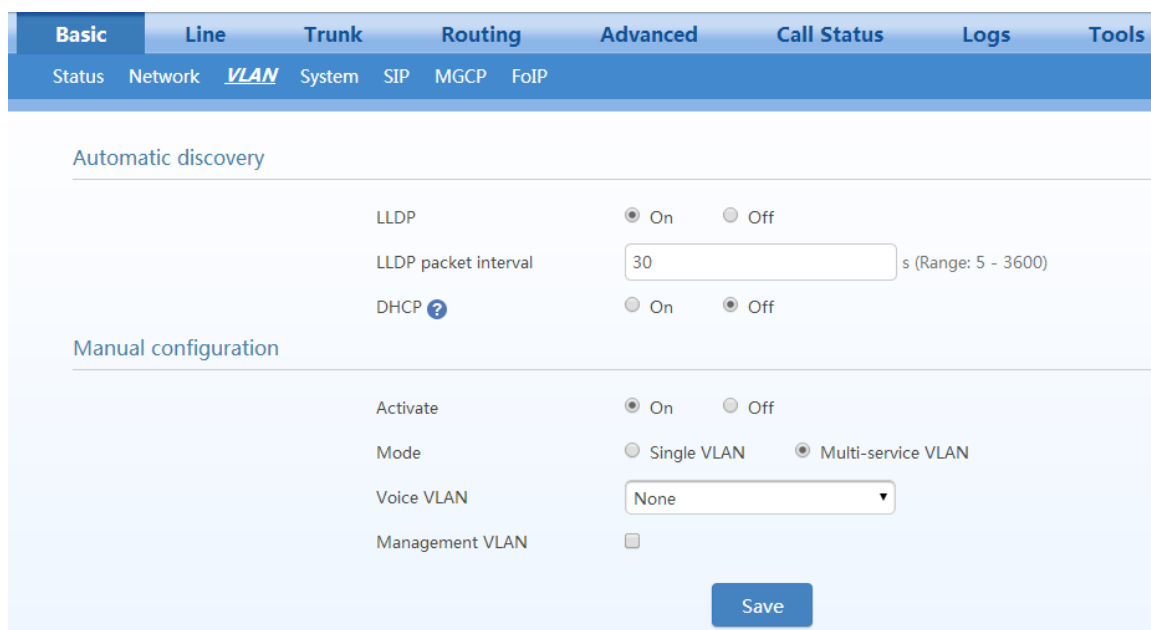

Discovery Mechanism

Figure 3-77 Scenario Diagram

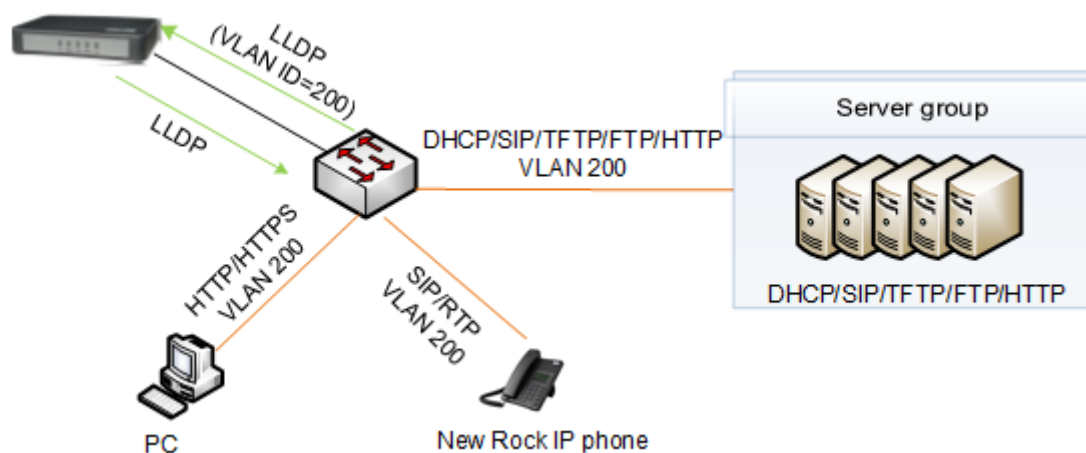

The process consists of the following steps:

The device periodically sends an LLDP message to notify the switch the device information. The sending interval is modifiable on the GUI interface. See Table 2-4.

At the same time, the device receives an LLDP message from the switch, and parses VLAN ID, Priority, and DSCP fields.

- If the message carries a VLAN ID, the device enables the VLAN, adds VLAN information to the next messages to be sent, and obtains network information such as an IP address via DHCP.

If the VLAN is also manually enabled on the GUI interface, its VLAN information will be replaced by the information that the device has obtained from the LLDP message.

- If the message does not carry a VLAN ID, the device checks whether the VLAN is manually enabled. If the VLAN is manually enabled, the device uses the VLAN information configured manually; otherwise, the device enters the non-VLAN communication status.

- **Handling Procedure When the LLDP Message Carries a VLAN ID**

The device detects whether the LLDP message carries a VLAN ID upon startup only. Once a VLAN ID is detected, the device enables the VLAN, adds VLAN information to the next messages to be sent, and obtains network information such as an IP address via DHCP. The device ignores any subsequent LLDP message with different VLAN ID. Figure 3-78 shows the handling procedure.

Figure 3-78 Procedure of Handling LLDP Message Carrying a VLAN ID

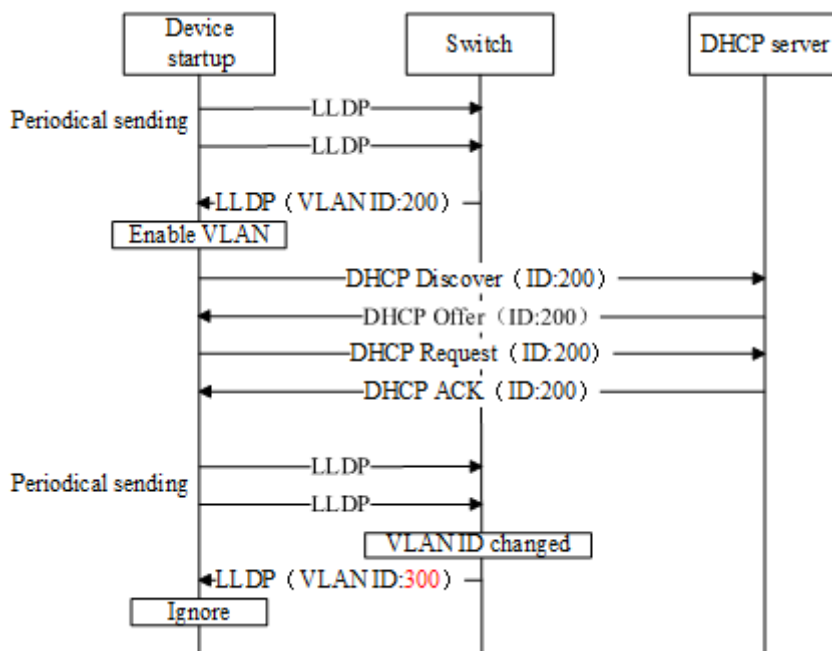

- Procedure of Handling the LLDP Message with no VLAN ID

During startup period, if the device receives LLDP messages with no VLAN ID, it uses the VLAN information configured manually. Figure 3-79 shows the handling procedure.

Figure 3-79 Procedure of Handling the LLDP Message with no VLAN ID

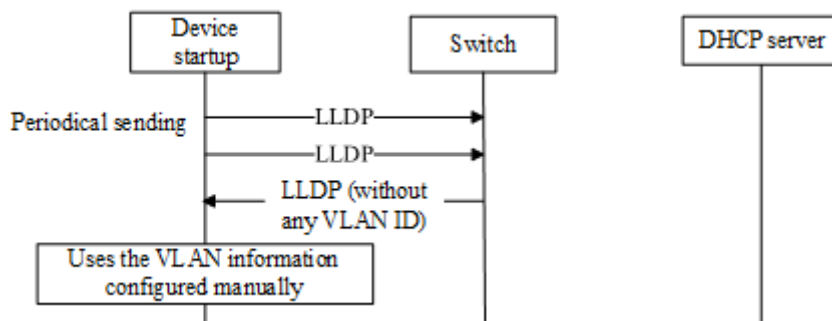

Messages

- LLDP Message

Upon receipt of an LLDP message, the device will check if the VLAN ID, Priority, and DSCP fields are included.

Figure 3-80 shows the LLDP message.

Figure 3-80 LLDP Message

```

Link Layer Discovery Protocol
+ Chassis Subtype = MAC address, Id: 00:0e:a9:20:33:66
+ Port Subtype = MAC address
+ Time To Live = 120 sec
+ System Name = VoIP-AG
+ System Description = VoIP Gateway
+ Capabilities
+ Management Address
+ Port Description = eth0
+ IEEE 802.1 - VLAN Name
+ IEEE 802.3 - Link Aggregation
+ IEEE 802.3 - MAC/PHY Configuration/Status
+ TIA TR-41 Committee - Media Capabilities
+ TIA TR-41 Committee - Inventory - Software Revision
+ TIA TR-41 Committee - Network Policy
  1111 111. .... .... = TLV Type: Organization specific (127)
  .... ...0 0000 1000 = TLV Length: 8
  Organization Unique Code: 0x0012bb
  Media subtype: Network Policy (0x02)
  Application Type: Voice (1)
  0... .... .... .... = Policy: Defined
  .1.. .... .... .... = Tagged: Yes
  ...0 0001 1001 000. = VLAN Id: 200
  .... ...1 01.. .... = L2 Priority: 5
  ..10 1110 = DSCP Value: 46
+ End of LLDPDU
    
```

● Sent Message with a VLAN ID

After obtaining a VLAN ID from the LLDP message, the device adds the VLAN information to the Ethernet frame headers of all messages to be sent. In addition, the device adds a DSCP value to the RTP message. Figure 3-81 shows the sent message with a VLAN ID.

Figure 3-81 Adding a VLAN ID to the Message to Be Sent

```

Frame 41: 218 bytes on wire (1744 bits), 218 bytes captured (1744 bits) on interface 0
Ethernet II, Src: Shanghai_00:26:90 (00:0e:a9:00:26:90), Dst: Shanghai_05:14:07 (00:0e:a9:05:14:07)
802.1Q Virtual LAN, PRI: 5, CFI: 0, ID: 200
  101. .... .... .... = Priority: Video, < 100ms latency and jitter (5)
  ...0 .... .... .... = CFI: Canonical (0)
  .... 0000 1100 1000 = ID: 200
  Type: IP (0x0800)
Internet Protocol Version 4, Src: 10.128.10.173 (10.128.10.173), Dst: 10.128.88.120 (10.128.88.120)
  Version: 4
  Header length: 20 bytes
  Differentiated Services Field: 0xb8 (DSCP 0x2e: Expedited Forwarding; ECN: 0x00: Not-ECT (Not ECN-capable Transport))
    1011 10.. = Differentiated Services Codepoint: Expedited Forwarding (0x2e)
    .... ..00 = Explicit Congestion Notification: Not-ECT (Not ECN-capable Transport) (0x00)
  Total Length: 200
  Identification: 0x0000 (0)
  Flags: 0x02 (Don't Fragment)
    0... .... = Reserved bit: Not set
    .1.. .... = Don't fragment: Set
    
```

3.1.2 DHCP

The device obtains the VLAN tag and QoS using DHCP option 132 and option 133 from DHCP server. Be ensured that DHCP option 132 and DHCP option 133 are properly configured on the DHCP server.

Configuration

After login, click **Basic > VLAN**. Set **DHCP** to be **On**, and then click **Save**. In addition, ensure DHCP is set on the **Basic > Network** page.

The screenshot shows the configuration page for VLAN. The navigation bar includes tabs for Basic, Line, Trunk, Routing, Advanced, Call Status, Logs, and Tools. Below this, there are sub-tabs for Status, Network, VLAN (selected), System, SIP, MGCP, and FoIP. The main configuration area is divided into two sections: Automatic discovery and Manual configuration. In the Automatic discovery section, there are two rows of radio buttons. The first row is for LLDP, with 'On' and 'Off' options. The second row is for DHCP, with 'On' and 'Off' options. The 'DHCP' row is highlighted with a red box, and the 'On' radio button is selected. In the Manual configuration section, there is one row of radio buttons for 'Activate', with 'On' and 'Off' options. The 'Off' radio button is selected. A 'Save' button is located at the bottom right of the configuration area.

Discovery Mechanism

1. The device periodically sends DHCPDISCOVER message carrying with option 132 and option 133 to the DHCP server.
2. The DHCP server returns DHCPOFFER message in response.
3. The device sets the global VLAN by using the values in option 132 and option 133 carried in DHCPOFFER message and will reboot after that.
4. The VLAN is established after the device reboots.
5. The device will update its VLAN settings if the values in option 132 and option 133 carried in DHCPOFFER change and reboot will be made after that.

Messages

1. DHCPDISCOVER message sent from the device to the DHCP server

```
Option: (55) Parameter Request List
Length: 12
Parameter Request List Item: (1) Subnet Mask
Parameter Request List Item: (3) Router
Parameter Request List Item: (6) Domain Name Server
Parameter Request List Item: (12) Host Name
Parameter Request List Item: (15) Domain Name
Parameter Request List Item: (28) Broadcast Address
Parameter Request List Item: (42) Network Time Protocol Servers
Parameter Request List Item: (66) TFTP Server Name
Parameter Request List Item: (67) Bootfile name
Parameter Request List Item: (120) SIP Servers
Parameter Request List Item: (132) PXE - undefined (vendor specific)
Parameter Request List Item: (133) PXE - undefined (vendor specific)
```

2. DHCPOFFER returned by the DHCP server

```
Option: (132) PXE - undefined (vendor specific)
Length: 3
Value: 323030
Option: (133) PXE - undefined (vendor specific)
Length: 1
Value: 37
```

3.2 Manual Configuration

3.2.1 Single VLAN

All services of the device are on the same VLAN, and the device receives only data packets carrying the VLAN and includes the VLAN tag in all sent data packets. In the single VLAN mode, all device services belong to the same VLAN. The device receives only data packets that carry the VLAN tag and includes the VLAN tag in all sent data packets. In this mode, the physical network port of the device has no separate address and shares the IP address of the VLAN interface.

Configuration

On the web interface, click **Basic > VLAN**, set the Activate to **On**, set **Mode** to **Single VLAN**, enter the VLAN tag, and specify network information such as IP address or select **DHCP**. As shown in Figure 3-82.

Figure 3-82 Configuring the Single VLAN

Basic	Line	Trunk	Routing	Advanced	Call Status	Logs	Tools
Status	Network	VLAN	System	SIP	MGCP	FoIP	
Automatic discovery							
		LLDP		<input type="radio"/> On	<input checked="" type="radio"/> Off		
		DHCP ?		<input type="radio"/> On	<input checked="" type="radio"/> Off		
Manual configuration							
		Activate		<input checked="" type="radio"/> On	<input type="radio"/> Off		
		Mode		<input checked="" type="radio"/> Single VLAN	<input type="radio"/> Multi-service VLAN		
		VLAN tag		<input type="text" value="0"/>	(Range: 3 - 4093)		
		VLAN QoS		<input type="text" value="0 (Best effort)"/>			
		IP address assignment		<input type="text" value="Static"/>			
		IP address		<input type="text" value="192 . 168 . 2 . 218"/>			
		Netmask		<input type="text" value="255 . 255 . 0 . 0"/>			
		Gateway IP address		<input type="text" value="192 . 168 . 2 . 1"/>			
		MTU		<input type="text" value="1500"/>	(Range: 576 - 1500)		
<input type="button" value="Save"/>							

Example of Single VLAN

Configure the device to work in single VLAN mode with a corresponding VLAN tag of 200, and restart the device. Check that all data packets sent by the device carry a VLAN ID 200, as shown in Figure 3-83.

Figure 3-83 A Data Packet Carrying a Corresponding VLAN Tag in the Single VLAN Mode

```

# Frame 15: 418 bytes on wire (3344 bits), 418 bytes captured (3344 bits) on interface 0
# Ethernet II, Src: Shanghai_00:26:90 (00:0e:a9:00:26:90), Dst: Shanghai_00:03:04 (00:0e:a9:00:03:04)
# 802.1Q Virtual LAN, PRI: 5, CFI: 0, ID: 200
  101. .... = Priority: video, < 100ms latency and jitter (5)
  .... = CFI: Canonical (0)
  .... 0000 1100 1000 = ID: 200
  Type: IP (0x0800)
# Internet Protocol Version 4, Src: 10.128.10.130 (10.128.10.130), Dst: 192.168.88.120 (192.168.88.120)
# User Datagram Protocol, Src Port: sip (5060), Dst Port: sip (5060)
# Session Initiation Protocol (REGISTER)

```

3.2.2 Multi-Service VLAN

In the multi-service VLAN mode, the device can configure a VLAN tag, a priority for the voice service (SIP signaling and RTP/T.38 media stream), and a management service (HTTP/HTTPS, Telnet,). The device carries a different VLAN tag in data packets for different services. In this mode, the physical network port of the device can have a separate address or obtain an address from a non-VLAN network.

Configuring Voice VLAN

The device includes a VLAN tag configured in the voice VLAN in SIP, RTP and T.38 data packets.

The voice VLAN of the device has the following two modes: Mode 1 and Mode 2.

- **Mode1 - Signaling (SIP) and media stream (RTP/T.38) are on the same VLAN**



Note

In this mode, the voice VLAN can be configured with a separate IP address.

On the web interface, click **Network**, and ensure that the VLAN function is set to **On** and **Mode** is set to **Multi-service VLAN**. Select **Mode 1** for **Voice VLAN**, enter the VLAN tag, and specify network information such as IP address.

Figure 3-84 Configuring Voice VLAN to Work in Mode 1

- **Mode2 - Signaling (SIP) and media stream (RTP/T.38) are divided into different VLANs**



Note

In this mode, the voice VLAN cannot be configured with a separate address but shares the IP address of the VLAN interface of the device.

On the web interface, click **Basic > VLAN**, and ensure that the VLAN function is set to **On**, and **Mode** is set to **Multi-service VLAN**. Select **Mode 2** for **Voice VLAN**, and specify VLAN tags for SIP and RTP/T.38.

Figure 3-85 Configuring Voice VLAN to Work in Mode 2

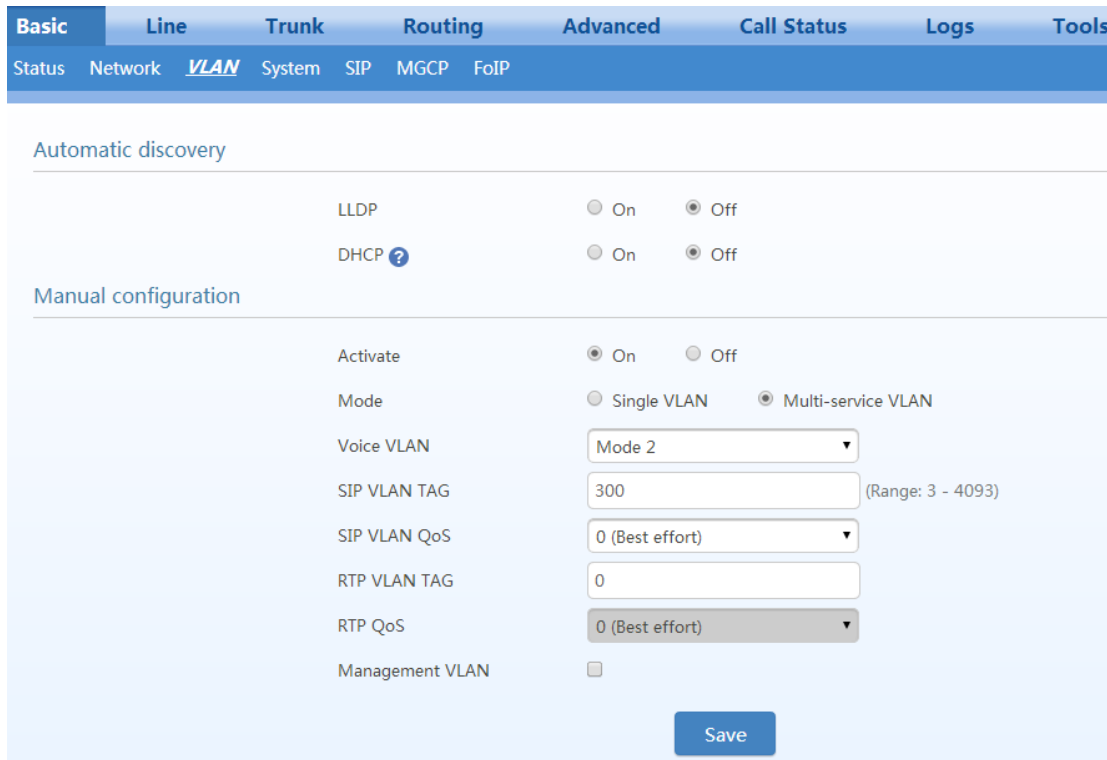

Configuring Management VLAN

The device adds VLAN tag configured in the management VLAN for HTTP, HTTPS and Telnet packets. On the web interface, click **Basic > VLAN**, and ensure that the VLAN function is set to **On** and **Mode** is set to **Multi-service VLAN**. Select **Management VLAN**, set the VLAN tag of the management service, and specify network information such as **IP address**.

Figure 3-86 Configuring Management VLAN

Management VLAN	<input checked="" type="checkbox"/>
VLAN tag	<input type="text" value="200"/>
VLAN QoS	<input type="text" value="0 (Best effort)"/>
IP address assignment	<input type="text" value="DHCP"/>
IP address	<input type="text" value="192.170.2.218"/>
Netmask	<input type="text" value="255.255.0.0"/>
Gateway IP address	<input type="text" value="192.170.1.1"/>

Example of Multi-Service VLAN

Figure 3-87 shows the network environment. The ports for connecting the switch and HX4 are added to VLAN 200 and VLAN 300. The port for connecting the switch and SIP server is added to VLAN 300. The ports for connecting the switch to the PC (used for managing HX4), are added to VLAN 200.

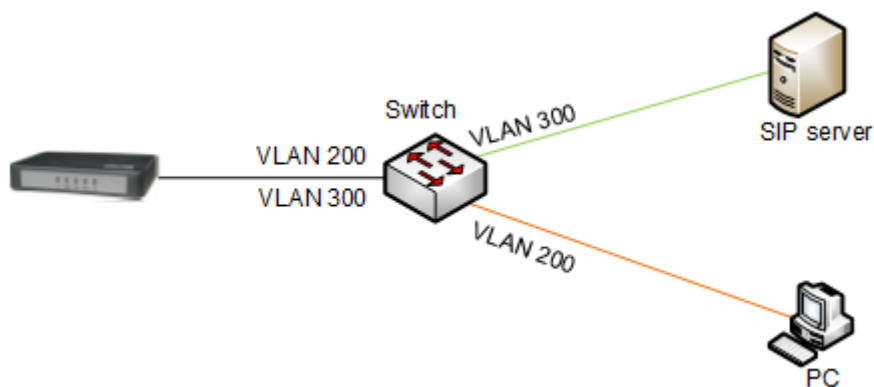
Figure 3-87 Network Environment

2. Configure multi-service VLAN on the HX4 device: the voice VLAN uses mode 1, the VLAN tag is 300, the VLAN tag of the management VLAN is 200, and the IP address is obtained from the corresponding VLAN network using DHCP. As shown in Figure 3-88.

Figure 3-88 Configuring Multi-Service VLAN

VLAN

Activate On Off

Mode Single VLAN Multi-service VLAN

Voice VLAN Mode 1 ▼

VLAN tag 300

VLAN QoS 0 (Best effort) ▼

IP address assignment DHCP ▼

IP address 192.168.2.218

Netmask 255.255.0.0

Gateway IP address 192.168.2.1

MTU 1500 (Range: 576 - 1500)

Management VLAN

VLAN tag 200

VLAN QoS 0 (Best effort) ▼

IP address assignment DHCP ▼

IP address 192.170.2.218

Save

3. Restart the device for the VLAN to take effect.
4. Use the PC belonging to VLAN 200 to log in to the web page. On the Basic > Status page, the IP address of each interface of the device can be viewed as shown in Figure 3-89. From top to bottom: IP address of the device’s physical network port, IP address of the management VLAN, and IP address of the voice VLAN.

Figure 3-89 IP Addresses of the Device in Multi-Service VLAN

Basic	Line	Trunk	Routing	Advanced	Call Status	Logs	Tools
Status	Network	VLAN	System	SIP	MGCP	FoIP	
Local signaling port					5060	It is not recommended to use port 5060 to avoid SIP DoS attack. Click here to change it.	
Host name					MX8-II		
MAC address					00:0E:A9:39:03:2B		
Model					MX8A-4S/4		
IP address					192.168.250.187		
Management VLAN tag IP address					10.128.10.170		
Voice VLAN tag IP address					130.130.130.139		
SNTP					The synchronization failed Configuration		
System up time					1 day 0 hours 36 minutes 5 seconds		

5. Enable the device to register with the SIP server and call an extension number on the SIP server.

Check that VLAN tag 300 configured in the voice VLAN is carried in the SIP packet and RTP packet.

Figure 3-90 SIP Data Packet Carrying VLAN Tag of the Voice VLAN in the Multi-Service VLAN Mode

```

Frame 30: 789 bytes on wire (6312 bits), 789 bytes captured (6312 bits) on interface 0
Ethernet II, Src: Shanghai_00:26:90 (00:0e:a9:00:26:90), Dst: Shanghai_26:02:69 (00:0e:a9:26:02:69)
802.1Q Virtual LAN, PRI: 5, CFI: 0, ID: 300
 101. .... = Priority: Video, < 100ms latency and jitter (5)
  ...0 ... = CFI: Canonical (0)
  ... 0001 0010 1100 = ID: 300
Type: IP (0x0800)
Internet Protocol Version 4, Src: 130.130.130.100 (130.130.130.100), Dst: 188.66.11.10 (188.66.11.10)
User Datagram Protocol, Src Port: sip (5060), Dst Port: sip (5060)
Session Initiation Protocol (INVITE)
  Request-Line: INVITE sip:66207701@188.66.11.10 SIP/2.0
  Message Header
    Via: SIP/2.0/UDP 188.66.11.5:5060;rport;branch=z9hG4bK-168627469014055899411405589932
    To: <sip:66207701@188.66.11.10>
    From: "66207731" <sip:66207731@188.66.11.10>;tag=14055899411405589931-1
    Call-ID: 14055899411367473044-0@130.130.130.100
    CSeq: 100020 INVITE
    
```

Figure 3-91 RTP Data Packet Carrying VLAN Tag of the Voice VLAN in the Multi-Service VLAN Mode

```

Frame 37: 218 bytes on wire (1744 bits), 218 bytes captured (1744 bits) on interface 0
Ethernet II, Src: Shanghai_00:26:90 (00:0e:a9:00:26:90), Dst: Shanghai_26:02:69 (00:0e:a9:26:02:69)
802.1Q Virtual LAN, PRI: 5, CFI: 0, ID: 300
 101. .... = Priority: Video, < 100ms latency and jitter (5)
  ...0 ... = CFI: Canonical (0)
  ... 0001 0010 1100 = ID: 300
Type: IP (0x0800)
Internet Protocol Version 4, Src: 130.130.130.100 (130.130.130.100), Dst: 188.66.11.10 (188.66.11.10)
User Datagram Protocol, Src Port: 10010 (10010), Dst Port: 10070 (10070)
Real-Time Transport Protocol
  [Stream setup by SDP (frame 32)]
  10.. .... = Version: RFC 1889 version (2)
  ..0. .... = Padding: False
  ...0 .... = Extension: False
  .... 0000 = Contributing source identifiers count: 0
  0... .... = Marker: False
  Payload type: ITU-T G.711 PCMU (0)
    
```

6. Check that tag 200 of the management VLAN is carried in the HTTP packet for the PC management device Web GUI.

Figure 3-92 RTP Data Packet Carrying VLAN Tag of the Management VLAN in the Multi-Service VLAN Mode

```

Frame 1344: 777 bytes on wire (6216 bits), 777 bytes captured (6216 bits) on interface 0
Ethernet II, Src: AsustekC_74:a4:a6 (60:a4:4c:74:a4:a6), Dst: Shanghai_00:26:90 (00:0e:a9:00:26:90)
802.1Q Virtual LAN, PRI: 0, CFI: 0, ID: 200
 000. .... = Priority: Best Effort (default) (0)
  ...0 ... = CFI: Canonical (0)
  ... 0000 1100 1000 = ID: 200
Type: IP (0x0800)
Internet Protocol Version 4, Src: 10.128.10.135 (10.128.10.135), Dst: 10.128.10.130 (10.128.10.130)
Transmission Control Protocol, Src Port: serialgateway (1243), Dst Port: http (80), Seq: 1, Ack: 1, Len: 707
Hypertext Transfer Protocol
  GET /tab2.gif HTTP/1.1\r\n
  Accept: */*\r\n
  Referer: http://10.128.10.130/index1.htm\r\n
  Accept-Language: zh-CN\r\n
  User-Agent: Mozilla/4.0 (compatible; MSIE 8.0; windows NT 6.1; WOW64; Trident/4.0; SLCC2; .NET CLR 2.0.50727; .NET CLR 3.5.30729; .NET CLR 3.0.30729; .NET CLR 2.0.50727; .NET CLR 1.0.3705; .NET CLR 1.1.4322.2222; .NET CLR 1.0.3705; .NET CLR 1.1.4322.2222)\r\n
  Accept-Encoding: gzip, deflate\r\n
    
```

4 Making an OpenVPN Client Certification

When the device serves as the OpenVPN client, a certificate needs to be uploaded as described in 2.7.6 Certificate. To make a certificate, follow this procedure:

Obtain from the server the .ovpn file, or the “ca.crt”, “client.crt”, “client.key” and “ta.key files, and other information.

Step 1 Create a text file client.ovpn.

Step 2 Client.ovpn contains following contents:

```
# Could be tap or tun as required by the VPN server
dev tap
persist-tun
persist-key
# Encryption type as required by the VPN server
cipher AES-128-CBC
tls-client
tls-auth ta.key 1
# The address and the port of the VPN server
remote 192.168.143.235 1194
# Could be udp or tcp as required by the VPN server
proto udp
tls-remote yfadmin
comp-lzo
passtos
ns-cert-type server
<ca>
# Copy the content beginning with “-----BEGIN ...” and ending with “-----END ...” from ca.crt to replace the #
following content.
-----BEGIN CERTIFICATE-----

-----END CERTIFICATE-----
</ca>
<cert>
# Copy the content beginning with “-----BEGIN ...” and ending with “-----END ...” rom client.crt to replace the #
following content.
-----BEGIN CERTIFICATE-----

-----END CERTIFICATE-----
</cert>
<key>
# Copy the content beginning with “-----BEGIN ...” and ending with “-----END ...” from client.key to replace the #
following content.
```

```
-----BEGIN RSA PRIVATE KEY-----
```

```
-----END RSA PRIVATE KEY-----
```

```
</key>
```

```
<tls-auth>
```

```
# Copy the content beginning with "-----BEGIN ..." and ending with "-----END ..." from ta.key to replace the #  
following content.
```

```
-----BEGIN OpenVPN Static key V1
```

```
-----END OpenVPN Static key V1-----
```

```
</tls-auth>
```

Step 3 Save the file as the name of client.ovpn.

Step 4 Transform the format to UNIX. Take the UltraEdit as an example to describe the transform procedure, shown as the figure below.
After transformation, save the file.

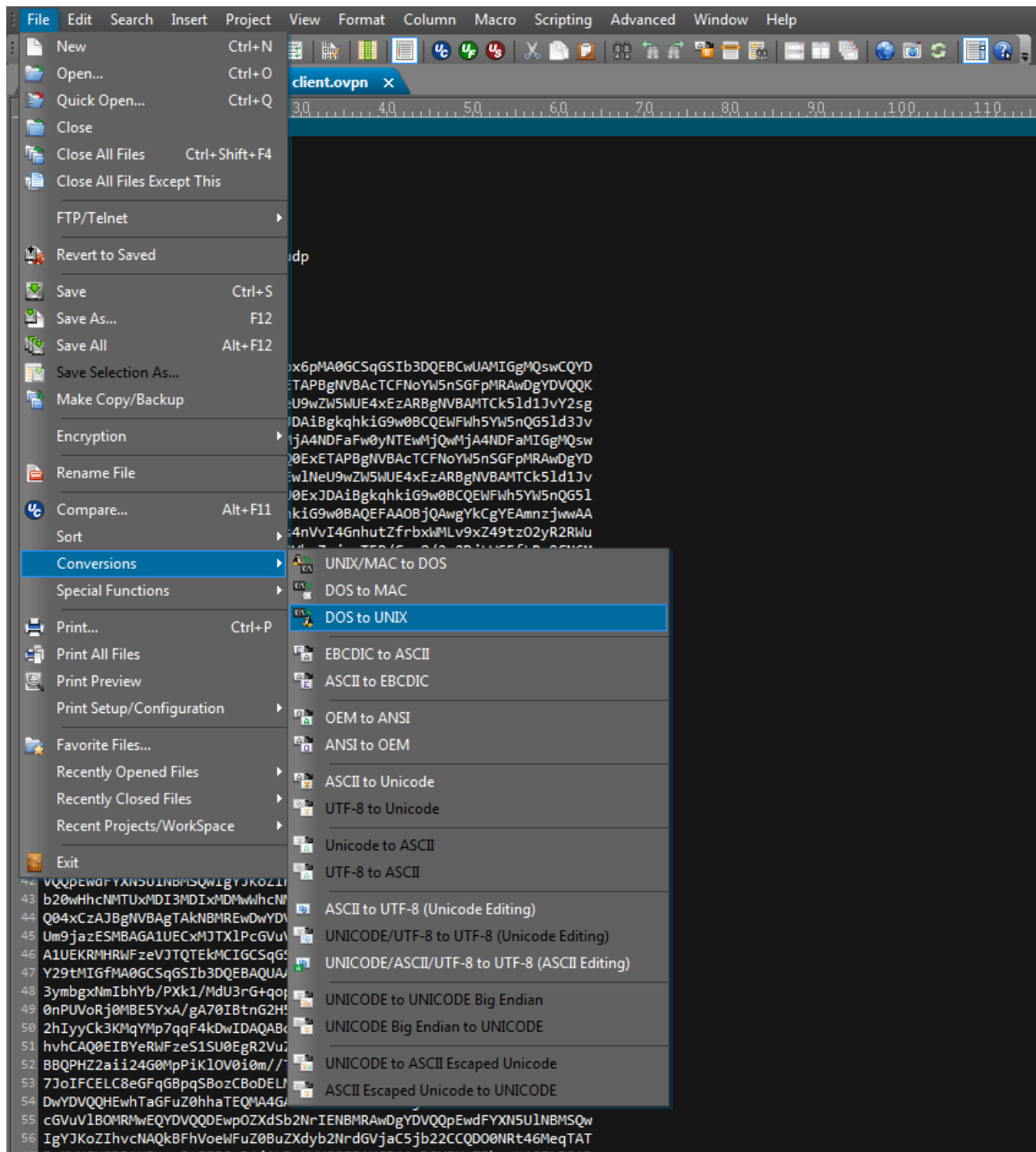

5 Appendix: High availability configuration

For configuration details, [High Availability Configuration Guide](#).

Note: If the link is unavailable, go to New Rock's official website: <http://newrocktech.com> to obtain the file from **Support > Download > [Task Guide] High Availability Configuration Guide**

6 Appendix: Auto provisioning configuration

MX8A/HX4E series voice gateways support auto provisioning, which allows users to manage gateway configuration and firmware upgrades remotely and centrally.

In this mode, users manage and store firmware upgrade packages and gateway configuration files on an automatic configuration server (ACS). The gateway can either access the ACS when the gateway is powered on, or access the ACS periodically according to configuration, then automatically download the latest firmware package or configuration files.

The auto provisioning of the gateway supports the following functions:

- Configuring all gateways or upgrading the firmware of all gateways, or selectively upgrading certain gateways
- Automatically updating all gateway parameters
- Supporting TFTP, FTP, HTTP or HTTPS mode
- Supporting auto provisioning and local management through web services
- Obtaining the address of the ACS from DHCP option 66 or by manual configuration

Auto provisioning features the following advantages:

- Supporting highly-efficient and low-cost deployment, management, and maintenance of gateways on a large scale
- Providing configuration file backup
- Enabling centralized management of configuration files to enhance account information security

For configuration details, see [Auto Provisioning Configuration Manual](#).

Note: If the link is unavailable, go to New Rock's official website: <http://newrocktech.com> to obtain the file from **Support > Download**.